

# SE 2200 Series

High Speed, Rigidity and Productivity Economical CNC Turning Center

HYUNDAI WIA CNC Turning Center

[www.wardcnc.com](http://www.wardcnc.com)

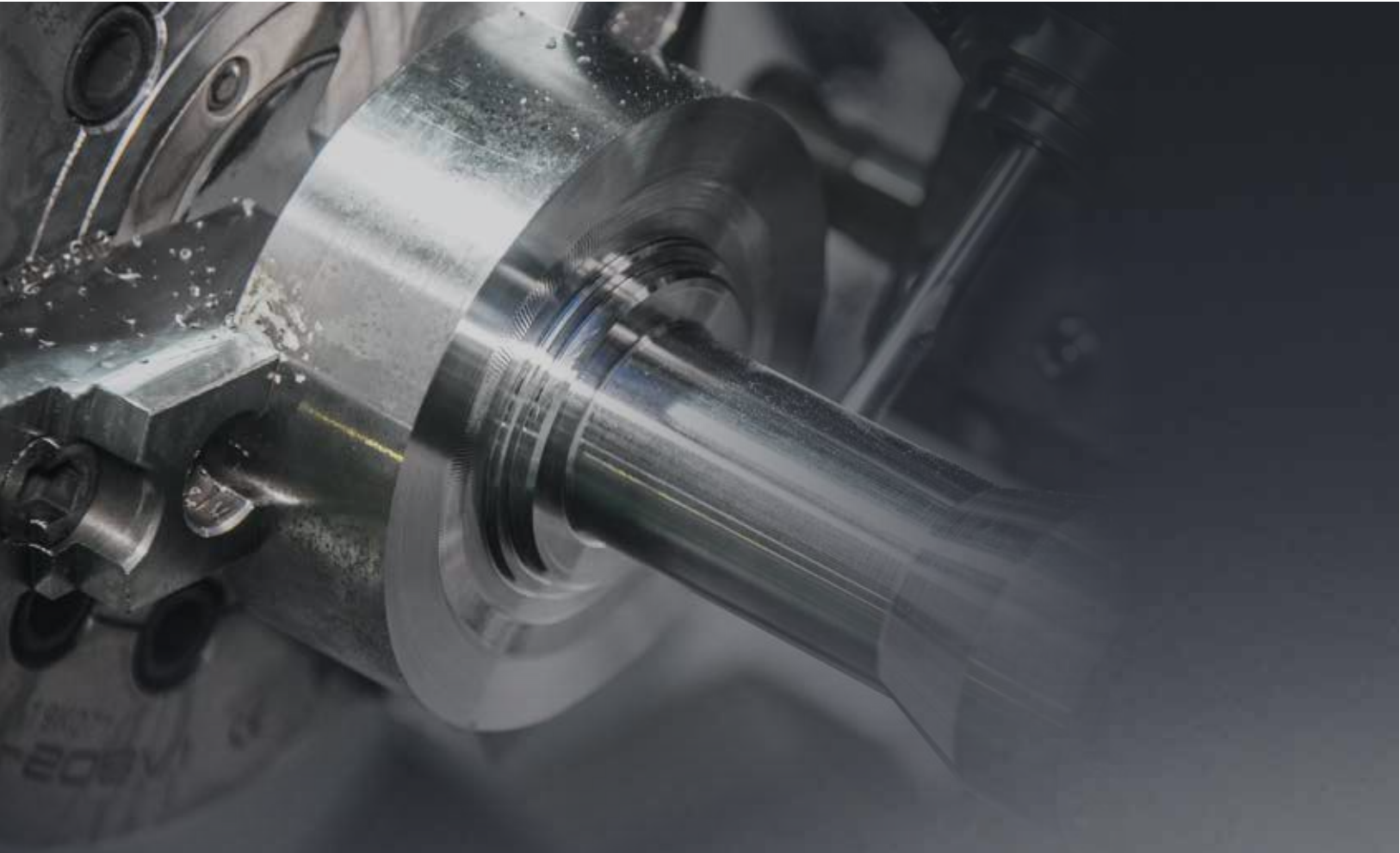

[www.wardcnc.com](http://www.wardcnc.com)

# Technical Leader

The CNC Turning Center SE Series, designed with HYUNDAI WIA's engineering expertise to maximize productivity by enhancing rigidity and accuracy of machining.

ITEM	Main Sp.			Sub Sp.	Bed Type		Turret	
	6"	8"	10"	5"	Std. Bed	Long Bed	Std. Turret	BMT45
SE2200A	•				•		•	
SE2200LA	•					•	•	
SE2200MA	•				•			•
SE2200LMA	•					•		•
SE2200LMSA	•			•	•			•
SE2200		•			•		•	
SE2200L		•				•	•	
SE2200M		•			•			•
SE2200LM		•				•		•
SE2200LMS		•		•	•			•
SE2200LC			•			•	•	
SE2200LMC			•			•		•
SE2200LMSC			•	•		•		•

# SE 2200 Series

Global-standard CNC Turning Center with High Speed, Rigidity and Productivity

- 30° slanted one-piece bed structure with high rigidity
- Ensured high-rigidity applying Roller guideway on all axes (X/Z-axis: 30/36m/min)
- Improved user convenience by applying the latest controller of FANUC
- Prepared user-oriented lineup including long-bed, mill turret and sub-spindle
- Compact structure with internal-motor design (for standard-type bed)
- Ergonomic design for convenient access to chuck and tool

[www.wardcnc.com](http://www.wardcnc.com)



[www.wardenc.com](http://www.wardenc.com)





# APPLICATIONS & PARTS

## Reduced machining time by HYUNDAI WIA's Technique

SE Series has been designed with robust box guide, spindle and travel system, maximizing precision and minimizing thermal displacement when process the products.

CARRIER PLANET



SHAFT



FLANGE



DRIVE GEAR



# MACHINING CAPABILITY

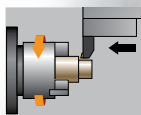

O.D Turning  
(Material : SM45C)

Machining Dia.	Ø80 mm (Ø3.1")
Machining depth	4 mm (0.16")
Cutting speed	215 m/min
Spindle rpm	856 r/min
Forwarding speed	0.5 mm/rev
Chip discharging amount	430 cc/min

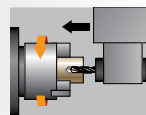

U-Drill  
(Material : SM45C)

Tool Dia.	Ø60 mm (Ø2.4")
Cutting speed	190 m/min
Spindle rpm	1,011 r/min
Forwarding speed	0.17 mm/rev
Chip discharging amount	486 cc/min

SE2200LM

❖ The above result might be different by types of processing circumstances.

www.wardcnc.com



# 01 BASIC STRUCTURE

The Best Productivity 6" / 8" / 10" Compact CNC Turning Center

## Mill Turret

- BMT45 (12 [24] Station)
- 6,000 r/min
- Collet Size : ER20 {Ø13 (Ø0.51")}

## Sub Spindle

- 5" / 6,000 r/min
- C-Axis Control : 0.001°

## High Precision Spindle

- Integral body & heat dissipating RIB structure.
- 6" : 6,000 r/min
- 8" : 4,500 r/min
- 10" : 3,500 r/min
- C-Axis Control : 0.001°

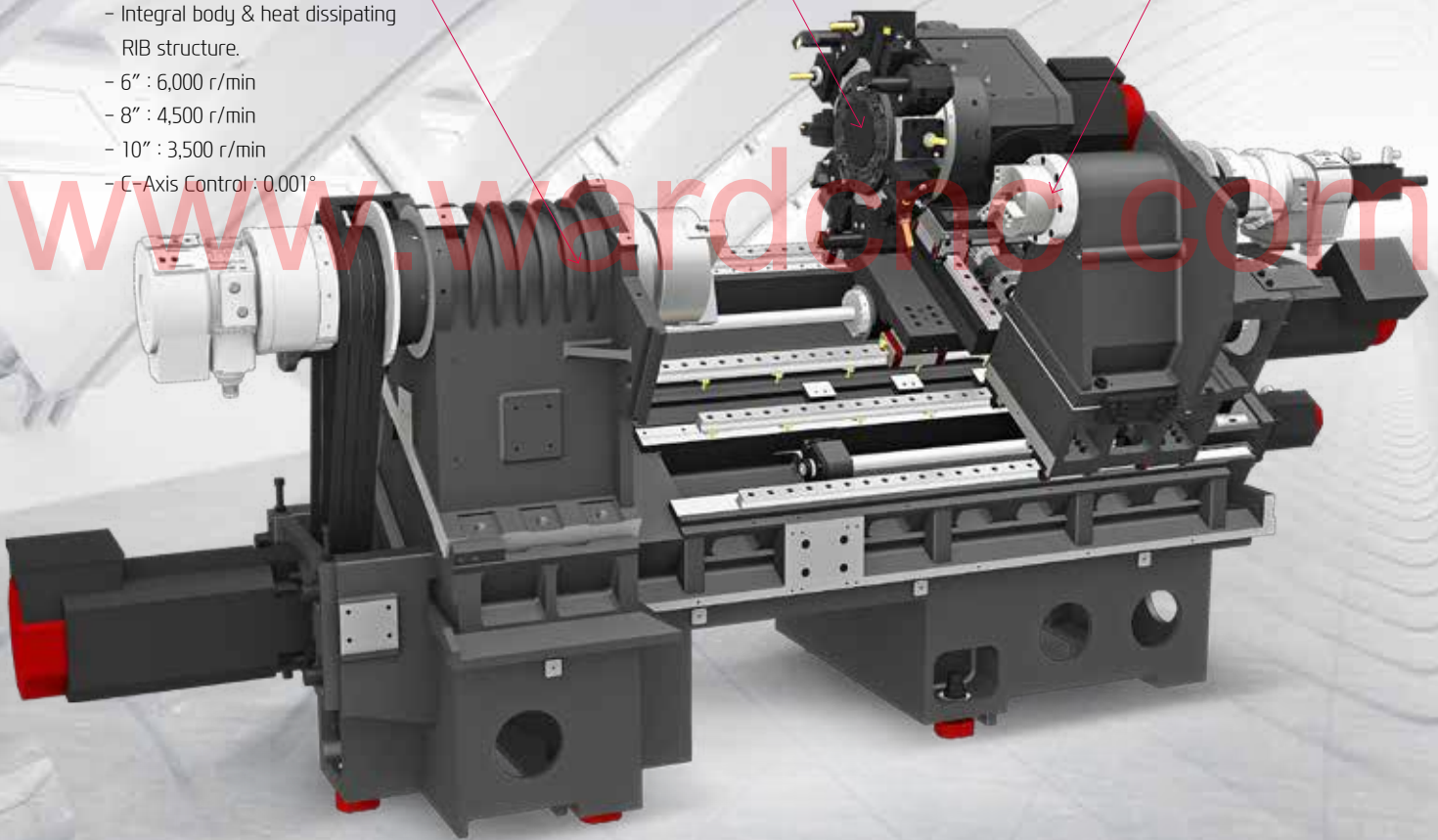

## Hydraulic NC Tail Stock with Positioning Control (Std. 'L')

The NC tail stock applied to SE2200 series is available to travel separately from the turret so as to achieve "increase in convinent of use" and "shortening of cycle time".

# REDUCTION OF NON-CUTTING TIME BY FAST RAPID SPEED

## ALL-IN-ONE TYPE OF BED

### Optimal Structural Analysis

Structural analysis was applied to the design of the machine to increase the tool post body and reduce the machine's height so as to maintain the bed's dynamic rigidity even during high-speed machining. In addition, the SE Series bed slope is pitched at 30 degrees to ensure more stable machining.



### ENHANCED VIBRATION ABSORPTION THANKS TO INCREASED GROUND AREA

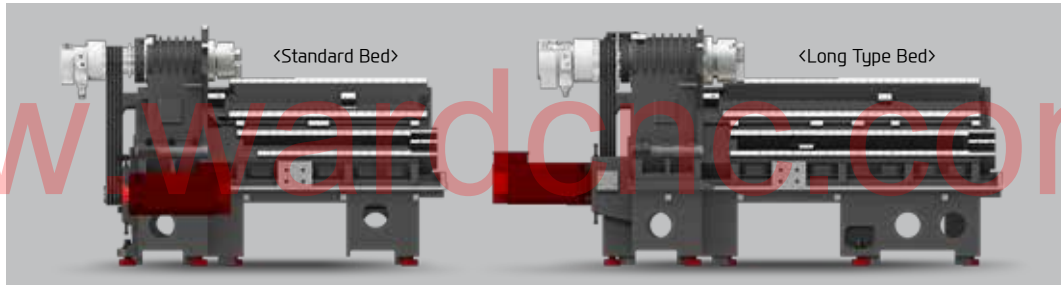

Floor Space (L×W) - Standard Bed

**2,120×1,610** mm (83.5"×63.4")

Floor Space (L×W) - Long Type Bed

**2,970×1,610** mm (116.9"×63.4")

## GUIDEWAY

### High-Speed Roller LM Guideway

Linear roller guideways are applied to reduce non-cutting time bring high rigidity.

### RIGIDITY HAS INCREASED 30% COMPARED TO THE BALL BEARING LM GUIDE

**Rapid Traverse Rate (X/Z) 30/36** m/min (1,181/1,417 ipm)

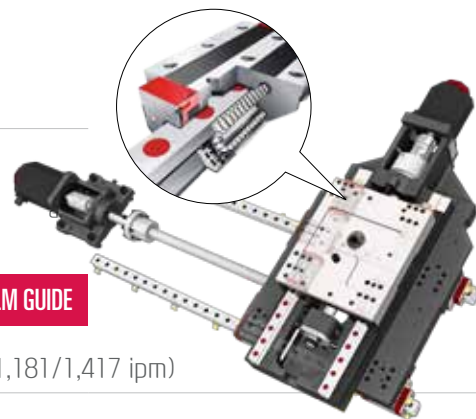

Travel (X/Z)

Standard Bed

**210/340** mm (8.3"/13.4")

Long Type Bed

**210/560** mm (8.3"/22")

www.wia-dnc.com



# 02 HIGH PRECISION SPINDLE

Long Lasting, High Accuracy & Excellent Performance CNC Turning Center

[www.wardcnc.com](http://www.wardcnc.com)

## Spindle Specifications

ITEM	Spindle Speed	Motor (Max./Cont.)	Torque (Max.)	Driving Method
6" Spindle	6,000 rpm (FANUC)	15/11 kW (20/15 HP)	127 N·m	Belt
	6,000 rpm (iTROL)	13.5/9 kW (18/12 HP)	114.5 N·m	
8" Spindle	4,500 rpm (FANUC)	15/11 kW (20/15 HP)	167 N·m	
	4,500 rpm (iTROL)	13.5/9 kW (18/12 HP)	150.3 N·m	
10" Spindle	3,500 rpm (FANUC)	18.5/11 kW (25/20 HP)	270 N·m	
	3,500 rpm (iTROL)	13.5/9 kW (18/12 HP)	197.6 N·m	
Sub Spindle	6,000 rpm (FANUC)	7.5/3.7 kW (10/5 HP)	63.6 N·m	
	6,000 rpm (iTROL)	7.4/4.9 kW (9.9/6.6 HP)	47 N·m	



# HEAVY DUTY CUTTING & HIGH ACCURACY

## MAIN SPINDLE

### Specialized in High-speed and Rough Cutting

The 6" main spindle is designed for high-speed machining by applying two and three-row ball bearings to the front and rear, respectively. In addition, the 8" and 10" main spindles are designed to match the rigid spindle structure by combining the double-row roller bearing and the angular contact bearing, which provides excellent performance for heavy-duty cutting.

Moreover, we applied the ribstar belt to minimize the slip and noise of the belt during processing, and this improvement enhanced performance of the work and increased processing stability by minimizing bearing damage caused by inflow of the oil.

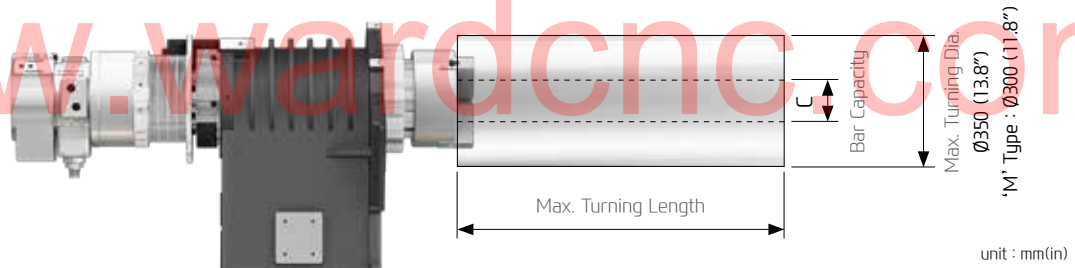

Max. Turning Length	Standard Bed		Long Type Bed		Bar Capacity
	Servo Turret	Mill Turret	Servo Turret	Mill Turret	
6 inch	340 (13.4")	309 (12.2")	560 (22")	529 (20.8")	Ø51 (Ø2")
8 inch	307 (12.1")	288 (11.3")	558 (22")	508 (20")	Ø65 (Ø2.6")
10 inch	-	-	549 (21.6")	499 (19.6")	Ø81 (Ø3.2")

❖ C-Axis Control ('M' Type)

C-axis of SE Series can be controlled to 0.001° which makes it possible to process various shapes.

## SUB SPINDLE ('S' Type)

The Belt-type sub spindle is designed to minimize thermal displacement during the continuous machining, offering from the heavy-duty cutting to the high-speed machining. When the main spindle cutting is completed, the sub spindle rotation is synchronized with the main spindle allowing the workpiece to be transferred to the sub spindle, and machining can begin on the back side of the workpiece.



www.wardcnc.com

# 03 SERVO TURRET

High speed, High Accuracy, Highly Reliable Servo Turret

[www.wardcnc.com](http://www.wardcnc.com)

## Servo Turret

No. of Tools

12<sub>EA</sub>

Tool Size (O.D/I.D)

□ 25/Ø40 mm (□ 1"/Ø1 1/2")

Indexing Time

0.15<sub>sec</sub>

## Mill Turret

Type	Speed	Motor (Max./Cont)	Torque (Max./Cont)	Collet Size
BMT45	6,000 rpm	FANUC : 2.75/1.85 kW (3.69/2.48 HP) iTROL : 2.8 kW (3.8 HP)	FANUC : 26.2/11.9 N·m iTROL : 27 N·m	ER20 / Ø13 (0.6")

Quantity of mill turret tools: Std. 2ea / Opt. 24ea - Various machining with increased capacity (Prior model : max. 12ea)

# VARIOUS DRIVEN PRECISION BMT TOOL HOLDERS

## SERVO TURRET

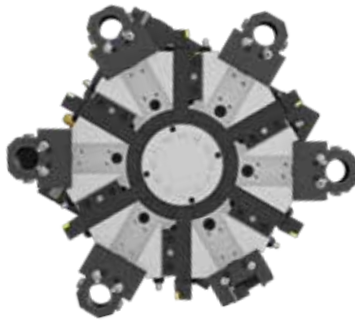

### Servo Turret

The turret of SE series is applied with high performance AC servo motor, improving machining reliability. 3-piece coupling shows excellent performance in indexing. Powerful hydraulic tool clamping minimizes tool tip deviation caused by load.

### 20 Bar(290 psi) High Pressure Coolant **OPTION**

Turret is designed to utilize 20 bar (290 psi) high pressure coolant and it shows optimum performance in machining difficult-to-cut material.



## MILL TURRET

### BMT45 Turret (Mill Turret)

The BMT turret secures the tool with four bolts and key on the tool mounting surface of the turret, making it possible to powerfully fix the tool, ensuring high reliability in rigidity and precision.



#### STRAIGHT MILLING HEAD



#### ANGULAR MILLING HEAD



### Mill Tool Holder

Machining capability has increased with the addition of straight milling head tool holder.

### Increased Rotating Tools

**Straight and angular milling haed 1ea > 2ea, respectively**



### Special Tool

**OPTION**

The SE series can process high value-added products using a variety of rotating tools. In particular, there is a multi-holder for attaching a variety of tools to one holder, and an eccentric rotary tool for handling eccentric parts without additional axis travel, which can realize integration of process with one machine.

❖ Consultation needed when ordering these options.



# 04 USER CONVENIENCE

Various Devices for User Friendly

## BAR FEEDER SYSTEM

### Bar Feeder

Bar feeder system enables automation which leads to efficiency improvement.

Long Type	: 3 m (118.1")	Short Type	: 1.5 m (59.1")
Bar Capacity	: Ø42 (1.7")	Bar Capacity	: Ø65 (2.6")



#### Parts Catcher

An optional parts catcher collects finished parts without the need to open the door, adding productivity, especially when a bar feeder is attached.

#### Parts Conveyor

The parts conveyor transfers the finished workpiece unloaded by the parts catcher for user convenience.



#### Auto Door

Using M-code, the doors can be automatically opened and closed which brings productivity and convenience for automation.

#### Auto Shutter

Using auto shutter, automation system with gantry loader is possible without opening the machine's door.

## HIGH PRECISION SYSTEM



### Automatic Q-Setter

Cutting tools are calibrated quickly and accurately with the addition of a q-setter. Each tool tip is touched off manually using a sensor that inputs the position automatically.



### Linear Scale

Linear scales increase positioning accuracy and reduce distortion caused by thermal growth, thus ensuring a more accurate finished part



### Work Probe

Workpiece coordinate values can be set automatically using the optional spindle probe.



Optional

## CHIP DISPOSAL SOLUTION

### Chip Conveyor

Timely and effective disposal of chips will enhance productivity as well as the working environment.

< Chip Discharge Height – Opt.1 : 860mm (33.9"), Opt. 2 : 1,200mm (47.2") >



Hinge	Chip Type : Roughing Chip, Long Chip, Chip complex	Material : SS41, 45C, Cast Steel	Front-Right Direction
	Highly efficient when disposing a lot of chips. Capable of handling stringy chips..		
Scraper	Chip Type : Finely broken chip blown out	Material : cast Iron, Nonferrous	
	Convenient for shortly cut chips.		
❖ Screw	Chip Type : The lower portion of micro-chips Compresses and ejects chips to reduce chip Trouble.	Material : Steel, Casting	
❖ Drum Filter	Chip Type : Powder, Micro Chip	Material : AL	
	Advantageous in precision, as the chips do not flow in to the coolant nozzle.		

❖ When ordering a screw or drum filter chip conveyor, prior consult with hyundai wia's sales person.

## COOLANT UNIT & ECO SYSTEM



Standard Coolant (Nozzle)



Chuck Coolant (Upper Chuck)



Chuck Air Blow (Upper Chuck)



Air Gun



### Grease Lubrication Device

- PLC control allows for timely supply of extremely small amount of grease
- System alarm (low level, line blockage)
- Oil skimmer is unnecessary
- Up to 60% reduction of annual maintenance costs compared to ordinary lubricant oil

# 05 HYUNDAI WIA FANUC – SMART PLUS

The Compatible All-round Control

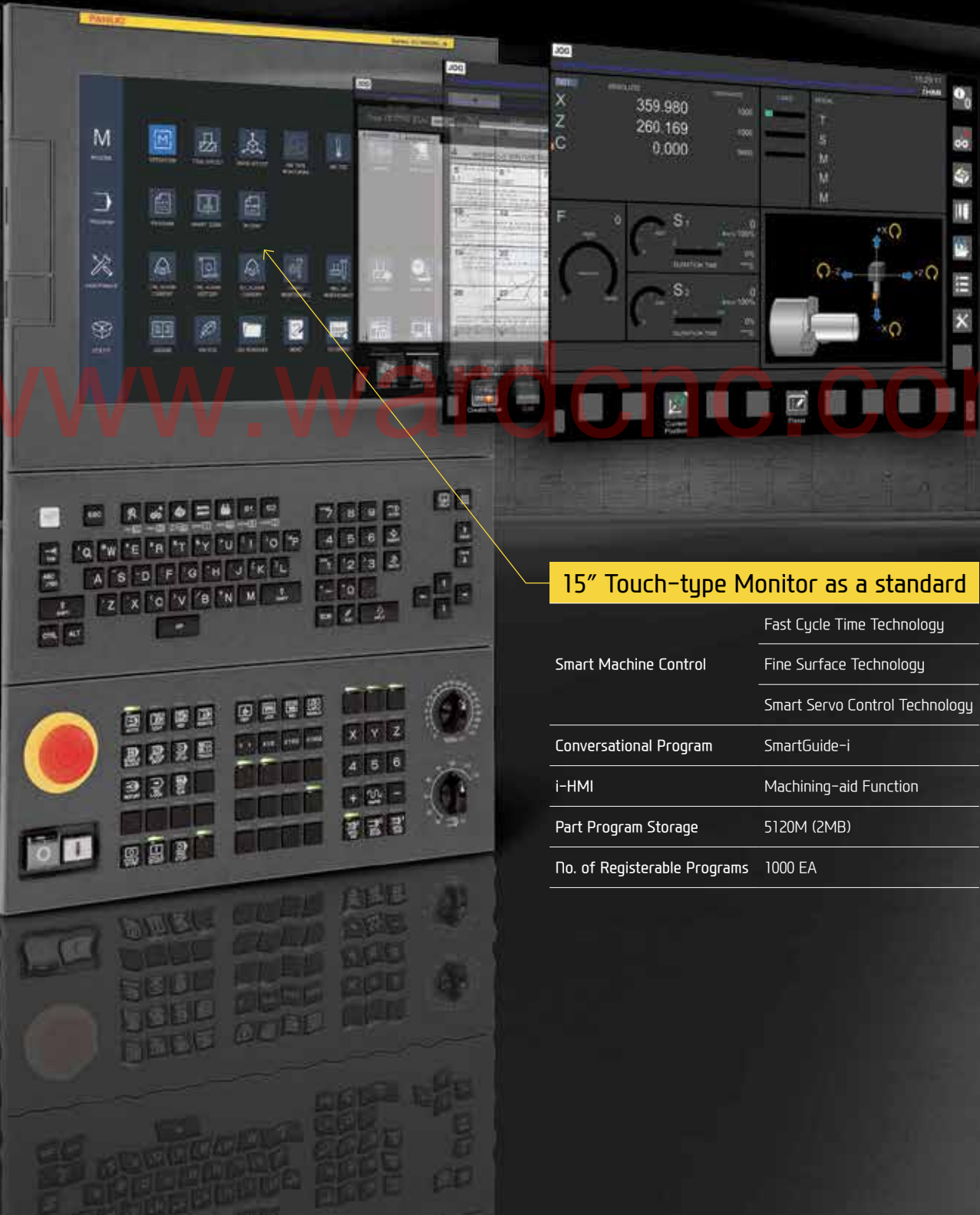

**15" Touch-type Monitor as a standard**

	Fast Cycle Time Technology
Smart Machine Control	Fine Surface Technology
	Smart Servo Control Technology
Conversational Program	SmartGuide-i
i-HMI	Machining-aid Function
Part Program Storage	5120M (2MB)
No. of Registerable Programs	1000 EA



# SMART SOFTWARE



## Dialogue Program (Smart Guide-i)

This software offers the maximum user convenience through dialogue manipulation from setup to processing. This includes writing processing programs and simulation checks.

## Convenience Function S/W



### 1. Thermal Displacement Compensation (HW-TDC) **OPTION**

This software improves processing precision by minimizing thermal deformation from changes in external environments and machining.

### 2. Machine Guidance (HW-MCG)

This software offers various user convenience functions such as tool manipulation, maintenance, tool monitoring, and a pop-up/status

### 3. LAUNCHER

This software offers shortcuts for quick access to specialized features and frequently used features.

### 4. Tool Monitoring (HW-TM) **OPTION**

This tool status monitoring software monitors and protects workpiece, tools, and equipment through real-time monitoring of the motor load from machining.

## Machining Support S/W

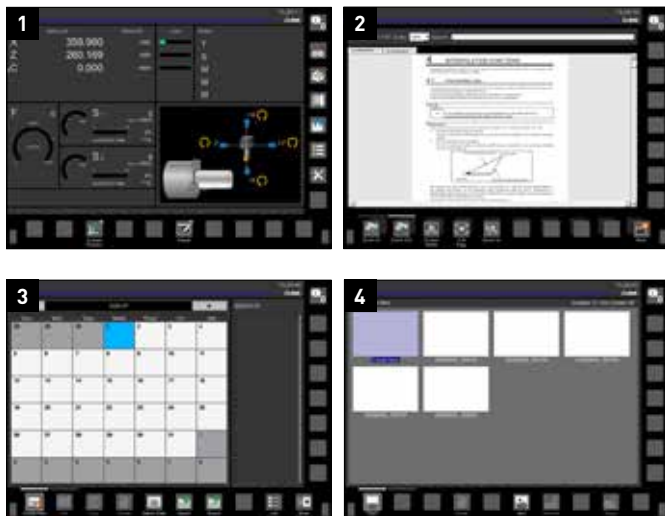

### 1. Premium Tool Operation

This software offers premium graphic functions for more intuitive tool operation. (Only in iHMI tools)

### 2. Manual Viewer

This software enables users to view electronic manuals right from the tool. (Only in iHMI tools)

### 3. Scheduling

This software enables viewing/setting up directly from the tool. This allows such actions as managing customer's tool schedules and schedule notification. (Only in iHMI tools)

### 4. Operation Memo

This software is capable of managing customer notes such as tool information and issues. (Only in iHMI tools)

# SPECIFICATIONS

## SE2200A Series Standard & Optional

Spindle		A	MA	LA	LMA	LMSA
Main Sp. Hollow Chuck 3 Jaw	6"	●	●	●	●	●
Main Sp. Solid Chuck 3 Jaw	6"	○	○	○	○	○
Sub Sp. Hollow Chuck 3 Jaw	5"	-	-	-	-	●
Sub Sp. Solid Chuck 3 Jaw	5"	-	-	-	-	○
Standard Soft Jaw (1set)		●	●	●	●	●
Chuck Clamp Foot Switch		●	●	●	●	●
2 Steps Hyd. Pressure Device		○	○	○	○	○
Spindle Inside Stopper		☆	☆	☆	☆	☆
Main Spindle Cs-axis (0.001")		-	●	-	●	●
Sub Spindle Cs-axis (0.001")		-	-	-	-	●
Chuck Open/Close Confirmation Device		●	●	●	●	●
2 Steps Chuck Foot Switch		○	○	○	○	○
Sub Chuck Foot Switch		-	-	-	-	●
<b>Turret</b>						
Tool Holder		●	●	●	●	●
Mill Turret	BMT	-	●	-	●	●
Straight Milling Head (Axial)	Collet Type, 2ea	-	●	-	●	●
Angular Milling Head (Radial)	Collet Type, 2ea	-	●	-	●	●
Straight Milling Head (Axial)	Adapter Type	-	○	-	○	○
Angular Milling Head (Radial)	Adapter Type	-	○	-	○	○
Boring Sleeve		●	●	●	●	●
Drill Socket		○	○	○	○	○
U-Drill Cap		●	●	●	●	●
Angle Head		●	●	●	●	●
Angle Head		-	☆	-	☆	☆
<b>Tail Stock &amp; Steady Rest</b>						
Hydraulic NC Tail Stock (Std. Live Center)		○	○	●	●	-
High Precision Live Center		☆	☆	☆	☆	-
Tail Stock Foot Switch		○	○	○	○	-
<b>Coolant &amp; Air Blow</b>						
Standard Coolant (Nozzle)		●	●	●	●	●
Chuck Coolant (Upper Chuck)		○	○	○	○	○
Gun Coolant		○	○	○	○	○
Through Spindle Coolant (Only for Special Chuck)		☆	☆	☆	☆	☆
Chuck Air Blow (Upper Chuck)		○	○	○	○	○
Sub Chuck Air Blow		-	-	-	-	○
Turnmill Through Coolant		-	○	-	○	○
Tail Stock Air Blow (Upper Tail Stock)		○	○	○	○	-
Turret Air Blow		☆	☆	☆	☆	☆
Air Gun		○	○	○	○	○
Through Spindle Air Blow (Only for Special Chuck)		-	-	-	-	-
High Pressure Coolant	0.5Bar	●	●	●	●	●
	6Bar	○	○	○	○	○
	20Bar	○	○	○	○	○
	70Bar	○	○	○	○	○
Power Coolant System (For Automation)		☆	☆	☆	☆	☆
Coolant Chiller (When selecting Sub Tank Type, Chip Conveyor)		-	-	-	-	-
<b>Chip Disposal</b>						
Coolant Tank	Front(150 ℓ [39.6 gal])	●	●	-	-	-
	Front(200 ℓ [52.8 gal])	-	-	●	●	●
	Rear(150 ℓ [39.6 gal])	○	○	○	○	○
Chip Conveyor (Hinge/Scraper/Screw)	Front (Right)	○	○	○	○	○
	Rear (Rear)	○	○	○	○	○
Special Chip Conveyor (Drum Filter)		-	-	-	-	-
Chip Wagon	Standard (180 ℓ [47.5 gal])	○	○	○	○	○
	Swing (200 ℓ [52.8 gal])	○	○	○	○	○
	Large Size (330 ℓ [87.2 gal])	○	○	○	○	○
	Customized	☆	☆	☆	☆	☆
<b>Safety Device</b>						
Total Splash Guard		●	●	●	●	●
Back Spin Torque Limiter (BST)		●	●	●	●	●
Torque Limiter		○	○	○	○	○
Front Door Interlock		●	●	●	●	●
Chuck Hydraulic Pressure Maintenance Interlock		☆	☆	☆	☆	☆
<b>ETC</b>						
Tool Box		●	●	●	●	●
Customized Color	Need Munsell No.	☆	☆	☆	☆	☆
CAD & CAM		☆	☆	☆	☆	☆

● : Standard ○ : Option ☆ : Prior Consultation - : Non Applicable

Electric Device		A	MA	LA	LMA	LMSA
Call Light	1Color : ●	●	●	●	●	●
	2Color : ●	○	○	○	○	○
	3Color : ●	○	○	○	○	○
Call Light & Buzzer	3Color : ●	○	○	○	○	○
Electric Cabinet Light		○	○	○	○	○
Remote MPG		○	○	○	○	○
Work Counter	Digital	○	○	○	○	○
Total Counter	Digital	○	○	○	○	○
Tool Counter	Digital	○	○	○	○	○
Multi Tool Counter	6ea	○	○	○	○	○
	9ea	○	○	○	○	○
Electric Circuit Breaker		○	○	○	○	○
AVR (Auto Voltage Regulator)		☆	☆	☆	☆	☆
Transformer	25kVA	○	○	○	○	-
	30kVA	-	-	-	-	-
Auto Power Off		○	○	○	○	○
<b>Measurement</b>						
Q-Setter		○	○	○	○	○
Automatic Q-Setter		○	○	○	○	○
Work Close Confirmation Device (Only for Special Chuck)	TACO	○	○	○	○	○
	SMC	○	○	○	○	○
Work Setter		☆	☆	☆	☆	☆
Linear Scale	X axis	○	○	○	○	○
	Z axis	○	○	○	○	○
Coolant Level Sensor (Only for Chip Conveyor)		☆	☆	☆	☆	☆
<b>Environment</b>						
Air Conditioner	FANUC	○	○	○	○	○
	ITROL	○	○	○	○	●
Dehumidifier		○	○	○	○	○
Oil Mist Collector		☆	☆	☆	☆	☆
Oil Skimmer (Only for Chip Conveyor)		○	○	○	○	○
MQL (Minimal Quantity Lubrication)		☆	☆	☆	☆	☆
<b>Fixture &amp; Automation</b>						
Auto Door	High-speed	○	○	○	○	○
Auto Shutter (Only for Automatic System)		○	○	○	○	○
Sub Operation Pannel		☆	☆	☆	☆	☆
Bar Feeder Interface		○	○	○	○	○
Bar Feeder (FEDEK)		☆	☆	☆	☆	☆
Extra M-Code 4ea		○	○	○	○	○
Automation Interface		☆	☆	☆	☆	☆
I/O Extension (IN & OUT)	16 Contact	○	○	○	○	○
	32 Contact	○	○	○	○	○
Parts Catcher	Main SP.	○	○	○	○	○
	Sub SP.	-	-	-	-	○
Sub Spindle Work Pusher (Spring Type)		-	-	-	-	○
Sub Spindle Work Ejector (Pneumatic Type)		-	-	-	-	○
Turret Work Pusher (For Automation)		☆	☆	☆	☆	☆
Parts Conveyor (Required Main Parts Catcher)		○	○	○	○	○
Semi Automation System		☆	☆	☆	☆	☆
<b>Hyd. Device</b>						
Standard Hyd. Cylinder	Hollow	●	●	●	●	●
Standard Hyd. Unit (35bar (507.6 psi))	15 ℓ (4gal)	●	●	●	●	-
	20 ℓ (5.3gal)	-	-	-	-	●
<b>S/W</b>						
Conversational program	SmartGuide-i	●	●	●	●	●
	HW-DPRO	○	○	○	○	○
Thermal Displacement Compensation (HW-TDC)		○	○	○	○	○
Tool Monitoring (HW-TM)		○	○	○	○	○
Machine Guidance (HW-MCG)		●	●	●	●	●
Energy Saving System (HW-ESS)		●	●	●	●	●
DNC software (HW-eDNC)		○	○	○	○	○
Machine Monitoring System (HW-MMS)		○	○	○	○	○
Thermal Displacement Compensation Device		○	○	○	○	○
Premium Tool Operation		●	●	●	●	●
Manual Viewer		●	●	●	●	●
Scheduling		●	●	●	●	●
Operation Memo		●	●	●	●	●

❖ Thermal Displacement Compensation device is recommended, when more than 6 bar of high pressure coolant is applied, for the high quality machining.

Specifications are subject to change without notice for improvement.



# SPECIFICATIONS

## SE2200 Series Standard & Optional

● : Standard ○ : Option ☆ : Prior Consultation - : Non Applicable

		SE2200	M	L	LM	LMS
<b>Spindle</b>						
Main Sp. Hollow Chuck 3 Jaw	8"	●	●	●	●	●
Main Sp. Solid Chuck 3 Jaw	8"	○	○	○	○	○
Sub Sp. Hollow Chuck 3 Jaw	5"	-	-	-	-	●
Sub Sp. Solid Chuck 3 Jaw	5"	-	-	-	-	○
Standard Soft Jaw (1set)		●	●	●	●	●
Chuck Clamp Foot Switch		●	●	●	●	●
2 Steps Hyd. Pressure Device		○	○	○	○	○
Spindle Inside Stopper		☆	☆	☆	☆	☆
Main Spindle Cs-axis (0.001")		-	●	-	●	●
Sub Spindle Cs-axis (0.001")		-	-	-	-	●
Chuck Open/Close Confirmation Device		●	●	●	●	●
2 Steps Chuck Foot Switch		○	○	○	○	○
Sub Chuck Foot Switch		-	-	-	-	●
<b>Turret</b>						
Tool Holder		●	●	●	●	●
Mill Turret	BMT	-	●	-	●	●
Straight Milling Head (Axial)	Collet Type, 2ea	-	●	-	●	●
Angular Milling Head (Radial)	Collet Type, 2ea	-	●	-	●	●
Straight Milling Head (Axial)	Adapter Type	-	○	-	○	○
Angular Milling Head (Radial)	Adapter Type	-	○	-	○	○
Boring Sleeve		●	●	●	●	●
Drill Socket		○	○	○	○	○
U-Drill Cap		●	●	●	●	●
Angle Head		●	●	●	●	●
Angle Head		-	☆	-	☆	☆
<b>Tail Stock &amp; Steady Rest</b>						
Hydraulic NC Tail Stock (Std. Live Center)		○	○	●	●	-
High Precision Live Center		☆	☆	☆	☆	-
Tail Stock Foot Switch		○	○	○	○	-
<b>Coolant &amp; Air Blow</b>						
Standard Coolant (Nozzle)		●	●	●	●	●
Chuck Coolant (Upper Chuck)		○	○	○	○	○
Gun Coolant		○	○	○	○	○
Through Spindle Coolant (Only for Special Chuck)		☆	☆	☆	☆	☆
Chuck Air Blow (Upper Chuck)		○	○	○	○	○
Sub Chuck Air Blow		-	-	-	-	○
Turnmill Through Coolant		-	○	-	○	○
Tail Stock Air Blow (Upper Tail Stock)		○	○	○	○	-
Turret Air Blow		☆	☆	☆	☆	☆
Air Gun		○	○	○	○	○
Through Spindle Air Blow (Only for Special Chuck)		-	-	-	-	-
High Pressure Coolant	0.5Bar	●	●	●	●	●
	6Bar	○	○	○	○	○
	20Bar	○	○	○	○	○
	70Bar	○	○	○	○	○
Power Coolant System (For Automation)		☆	☆	☆	☆	☆
Coolant Chiller (When selecting Sub Tank Type, Chip Conveyor)		-	-	-	-	-
<b>Chip Disposal</b>						
Coolant Tank	Front(150 ℓ [39.6 gal])	●	●	-	-	-
	Front(200 ℓ [52.8 gal])	-	-	●	●	●
	Rear(150 ℓ [39.6 gal])	○	○	○	○	○
Chip Conveyor (Hinge/Scraper/Screw)	Front (Right)	○	○	○	○	○
	Rear (Rear)	○	○	○	○	○
Special Chip Conveyor (Drum Filter)		-	-	-	-	-
Chip Wagon	Standard (180 ℓ [47.5 gal])	○	○	○	○	○
	Swing (200 ℓ [52.8 gal])	○	○	○	○	○
	Large Size (330 ℓ [87.2 gal])	○	○	○	○	○
	Customized	☆	☆	☆	☆	☆
<b>Safety Device</b>						
Total Splash Guard		●	●	●	●	●
Back Spin Torque Limiter (BST)		●	●	●	●	●
Torque Limiter		○	○	○	○	○
Front Door Interlock		●	●	●	●	●
Chuck Hydraulic Pressure Maintenance Interlock		☆	☆	☆	☆	☆
<b>ETC</b>						
Tool Box		●	●	●	●	●
Customized Color	Need Munsel No.	☆	☆	☆	☆	☆
CAD & CAM		☆	☆	☆	☆	☆

		SE2200	M	L	LM	LMS
<b>Electric Device</b>						
Call Light	1Color : ●	●	●	●	●	●
	2Color : ●●	○	○	○	○	○
	3Color : ●●●	○	○	○	○	○
Call Light & Buzzer	3Color : ●●●B	○	○	○	○	○
Electric Cabinet Light		○	○	○	○	○
Remote MPG		○	○	○	○	○
Work Counter	Digital	○	○	○	○	○
Total Counter	Digital	○	○	○	○	○
Tool Counter	Digital	○	○	○	○	○
Multi Tool Counter	6ea	○	○	○	○	○
	9ea	○	○	○	○	○
Electric Circuit Breaker		○	○	○	○	○
AVR (Auto Voltage Regulator)		☆	☆	☆	☆	☆
Transformer	25kVA	○	○	○	○	○
	30kVA	-	-	-	-	-
Auto Power Off		○	○	○	○	○
<b>Measurement</b>						
Q-Setter		○	○	○	○	○
Automatic Q-Setter		○	○	○	○	○
Work Close Confirmation Device (Only for Special Chuck)	TACO	○	○	○	○	○
	SMC	○	○	○	○	○
Work Setter		☆	☆	☆	☆	☆
Linear Scale	X axis	○	○	○	○	○
	Z axis	○	○	○	○	○
Coolant Level Sensor (Only for Chip Conveyor)		☆	☆	☆	☆	☆
<b>Environment</b>						
Air Conditioner	FANUC	○	○	○	○	○
	iTROL	○	○	○	○	●
Dehumidifier		○	○	○	○	○
Oil Mist Collector		☆	☆	☆	☆	☆
Oil Skimmer (Only for Chip Conveyor)		○	○	○	○	○
MQL (Minimal Quantity Lubrication)		☆	☆	☆	☆	☆
<b>Fixture &amp; Automation</b>						
Auto Door	High-speed	○	○	○	○	○
Auto Shutter (Only for Automatic System)		○	○	○	○	○
Sub Operation Panel		☆	☆	☆	☆	☆
Bar Feeder Interface		○	○	○	○	○
Bar Feeder (FEDEK)		☆	☆	☆	☆	☆
Extra M-Code 4ea		○	○	○	○	○
Automation Interface		☆	☆	☆	☆	☆
I/O Extension (IN & OUT)	16 Contact	○	○	○	○	○
	32 Contact	○	○	○	○	○
Parts Catcher	Main SP.	○	○	○	○	○
	Sub SP.	-	-	-	-	○
Sub Spindle Work Pusher (Spring Type)		-	-	-	-	○
Sub Spindle Work Ejector (Pneumatic Type)		-	-	-	-	○
Turret Work Pusher (For Automation)		☆	☆	☆	☆	☆
Parts Conveyor (Required Main Parts Catcher)		○	○	○	○	○
Semi Automation System		☆	☆	☆	☆	☆
<b>Hyd. Device</b>						
Standard Hyd. Cylinder	Hollow	●	●	●	●	●
Standard Hyd. Unit {35bar (507.6 psi)}	15 ℓ (4gal)	●	●	●	●	-
	20 ℓ (5.3gal)	-	-	-	-	●
<b>S/W</b>						
Conversational program	SmartGuide-i	●	●	●	●	●
	HW-DPRO	○	○	○	○	○
Thermal Displacement Compensation (HW-TDC)		○	○	○	○	○
Tool Monitoring (HW-TM)		○	○	○	○	○
Machine Guidance (HW-MCG)		●	●	●	●	●
Energy Saving System (HW-ESS)		●	●	●	●	●
DNIC software (HW-eDNIC)		○	○	○	○	○
Machine Monitoring System (HW-MMS)		○	○	○	○	○
Thermal Displacement Compensation Device		○	○	○	○	○
Premium Tool Operation		●	●	●	●	●
Manual Viewer		●	●	●	●	●
Scheduling		●	●	●	●	●
Operation Memo		●	●	●	●	●
<b>ETC</b>						
Tool Box		●	●	●	●	●
Customized Color	Need Munsel No.	☆	☆	☆	☆	☆
CAD & CAM		☆	☆	☆	☆	☆

❖ Thermal Displacement Compensation device is recommended, when more than 6 bar of high pressure coolant is applied, for the high quality machining.

Specifications are subject to change without notice for improvement.

# SPECIFICATIONS

## SE2200C Series Standard & Optional

Spindle		LC	LMC	LMSC
Main Sp. Hollow Chuck 3 Jaw	10"	●	●	●
Main Sp. Solid Chuck 3 Jaw	10"	○	○	○
Sub Sp. Hollow Chuck 3 Jaw	5"	-	-	●
Sub Sp. Solid Chuck 3 Jaw	5"	-	-	○
Standard Soft Jaw (1set)		●	●	●
Chuck Clamp Foot Switch		●	●	●
2 Steps Hyd. Pressure Device		○	○	○
Spindle Inside Stopper		☆	☆	☆
Main Spindle Cs-axis (0.001")		-	●	●
Sub Spindle Cs-axis (0.001")		-	-	●
Chuck Open/Close Confirmation Device		●	●	●
2 Steps Chuck Foot Switch		○	○	○
Sub Chuck Foot Switch		-	-	●
<b>Turret</b>				
Tool Holder		●	●	●
Mill Turret	BMT	-	●	●
Straight Milling Head (Axial)	Collet Type, 2ea	-	●	●
Angular Milling Head (Radial)	Collet Type, 2ea	-	●	●
Straight Milling Head (Axial)	Adapter Type	-	○	○
Angular Milling Head (Radial)	Adapter Type	-	○	○
Boring Sleeve (U-drill Holder/Sleeve : Public Use)		●	●	●
Drill Socket		○	○	○
U-Drill Cap		●	●	●
Angle Head		●	●	●
Angle Head		-	☆	☆
<b>Tail Stock &amp; Steady Rest</b>				
Hydraulic F/C Tail Stock (Std. Live Center)		●	●	-
High Precision Live Center		☆	☆	-
Tail Stock Foot Switch		○	○	-
<b>Coolant &amp; Air Blow</b>				
Standard Coolant (Nozzle)		●	●	●
Chuck Coolant (Upper Chuck)		○	○	○
Gun Coolant		○	○	○
Through Spindle Coolant (Only for Special Chuck)		☆	☆	☆
Chuck Air Blow (Upper Chuck)		○	○	○
Sub Chuck Air Blow		-	-	○
Turnmill Through Coolant		-	○	○
Tail Stock Air Blow (Upper Tail Stock)		○	○	-
Turret Air Blow		☆	☆	☆
Air Gun		○	○	○
Through Spindle Air Blow (Only for Special Chuck)		-	-	-
High Pressure Coolant	0.5Bar	●	●	●
	6Bar	○	○	○
	20Bar	○	○	○
	70Bar	○	○	○
Power Coolant System (For Automation)		☆	☆	☆
Coolant Chiller (When Selecting Sub Tank Type, Chip Conveyor)		-	-	-
<b>Chip Disposal</b>				
Coolant Tank	Front(150 ℓ [39.6 gal])	-	-	-
	Front(200 ℓ [52.8 gal])	●	●	●
	Rear(150 ℓ [39.6 gal])	○	○	○
Chip Conveyor (Hinge/Scraper/Screw)	Front (Right)	○	○	○
	Rear (Rear)	○	○	○
Special Chip Conveyor (Drum Filter)		-	-	-
Chip Wagon	Standard (180 ℓ [47.5 gal])	○	○	○
	Swing (200 ℓ [52.8 gal])	○	○	○
	Large Size (330 ℓ [87.2 gal])	○	○	○
	Customized	☆	☆	☆
<b>Safety Device</b>				
Total Splash Guard		●	●	●
Back Spin Torque Limiter (BST)		●	●	●
Torque Limiter		○	○	○
Front Door Interlock		●	●	●
Chuck Hydraulic Pressure Maintenance Interlock		☆	☆	☆
<b>ETC</b>				
Tool Box		●	●	●
Customized Color	Need Munsell No.	☆	☆	☆
CAD & CAM		☆	☆	☆

● : Standard ○ : Option ☆ : Prior Consultation - : Non Applicable

Electric Device		LC	LMC	LMSC
Call Light	1Color : ●	●	●	●
	2Color : ●	○	○	○
	3Color : ●	○	○	○
Call Light & Buzzer	3Color : ●	○	○	○
Electric Cabinet Light		○	○	○
Remote MPG		○	○	○
Work Counter	Digital	○	○	○
Total Counter	Digital	○	○	○
Tool Counter	Digital	○	○	○
Multi Tool Counter	6ea	○	○	○
	9ea	○	○	○
Electric Circuit Breaker		○	○	○
AVR (Auto Voltage Regulator)		☆	☆	☆
Transformer	25kVA	○	○	-
	30kVA	-	-	○
Auto Power Off		○	○	○
<b>Measurement</b>				
Q-Setter		○	○	○
Automatic Q-Setter		○	○	○
Work Close Confirmation Device (Only for Special Chuck)	TACO	○	○	○
	SMC	○	○	○
Work Setter		☆	☆	☆
Linear Scale	X axis	○	○	○
	Z axis	○	○	○
Coolant Level Sensor (Only for Chip Conveyor)		☆	☆	☆
<b>Environment</b>				
Air Conditioner	FANUC	○	○	○
	ITROL	○	○	●
Dehumidifier		○	○	○
Oil Mist Collector		☆	☆	☆
Oil Skimmer (Only for Chip Conveyor)		○	○	○
MQL (Minimal Quantity Lubrication)		☆	☆	☆
<b>Fixture &amp; Automation</b>				
Auto Door	High-speed	○	○	○
Auto Shutter (Only for Automatic System)		○	○	○
Sub Operation Pannel		☆	☆	☆
Bar Feeder Interface		○	○	○
Bar Feeder (FEDEK)		☆	☆	☆
Extra M-Code 4ea		○	○	○
Automation Interface		☆	☆	☆
I/O Extension (IN & OUT)	16 Contact	○	○	○
	32 Contact	○	○	○
Parts Catcher	Main SP.	○	○	○
	Sub SP.	-	-	○
Sub Spindle Work Pusher (Spring Type)		-	-	○
Sub Spindle Work Ejector (Pneumatic Type)		-	-	○
Turret Work Pusher (For Automation)		☆	☆	☆
Parts Conveyor (Required Main Parts Catcher)		○	○	○
Semi Automation System		☆	☆	☆
<b>Hyd. Device</b>				
Standard Hyd. Cylinder	Hollow	●	●	●
Standard Hyd. Unit (35bar (507.6 psi))	15 ℓ (4gal)	●	●	-
	20 ℓ (5.3gal)	-	-	●
<b>S/W</b>				
Conversational program	SmartGuide-i	●	●	●
	HW-DPRO	○	○	○
Thermal Displacement Compensation (HW-TDC)		○	○	○
Tool Monitoring (HW-TM)		○	○	○
Machine Guidance (HW-MCG)		●	●	●
Energy Saving System (HW-ESS)		●	●	●
DNC software (HW-eDNC)		○	○	○
Machine Monitoring System (HW-MMS)		○	○	○
Thermal Displacement Compensation Device		○	○	○
Premium Tool Operation		●	●	●
Manual Viewer		●	●	●
Scheduling		●	●	●
Operation Memo		●	●	●

❖ Thermal Displacement Compensation device is recommended, when more than 6 bar of high pressure coolant is applied, for the high quality machining.  
Specifications are subject to change without notice for improvement.

# SPECIFICATIONS

## HYUNDAI WIA FANUC – SMART PLUS Spindle Output/Torque Diagram

### SE2200A Series 6,000 rpm

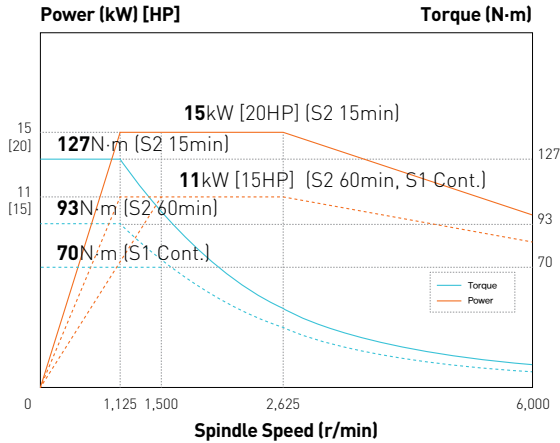

### SE2200 Series 4,500 rpm

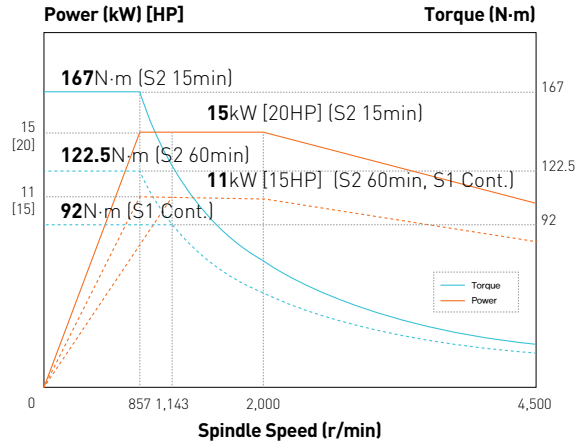

### SE2200C Series 3,500 rpm

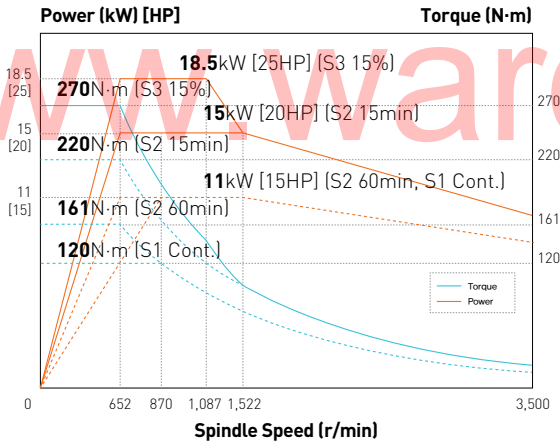

### Sub Spindle 6,000 rpm

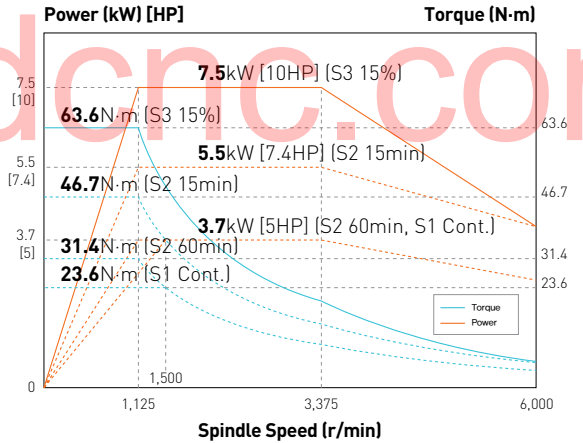

### Mill Turret 6,000 rpm

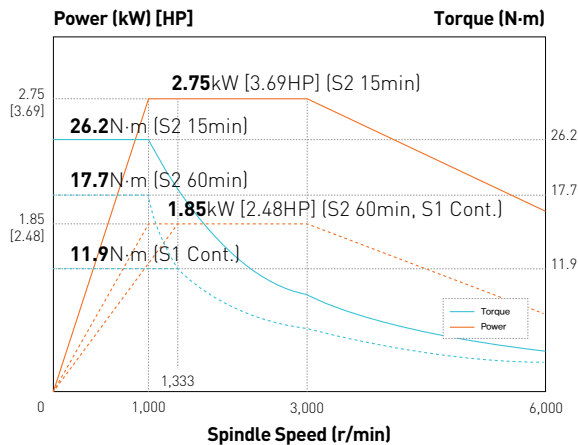

# SPECIFICATIONS

## HYUNDAI-iTROL Spindle Output/Torque Diagram

### SE2200A Series 6,000 rpm

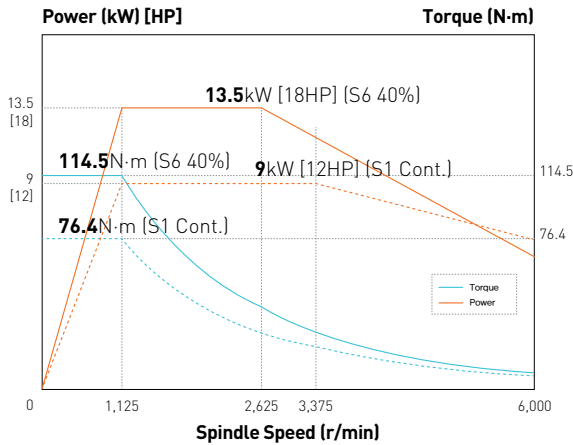

### SE2200 Series 4,500 rpm

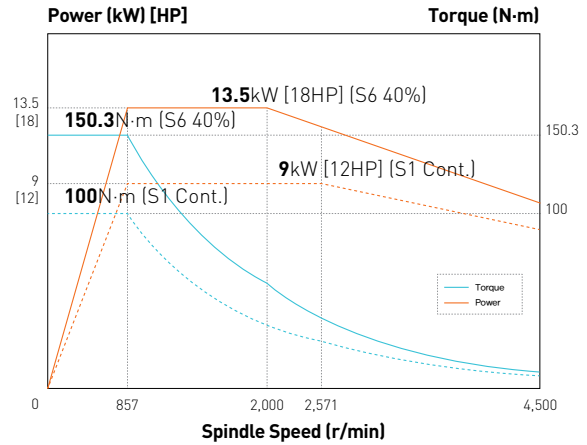

### SE2200C Series 3,500 rpm

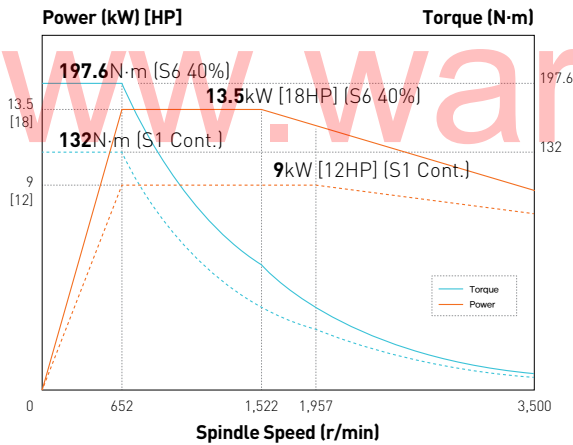

### Sub Spindle 6,000 rpm

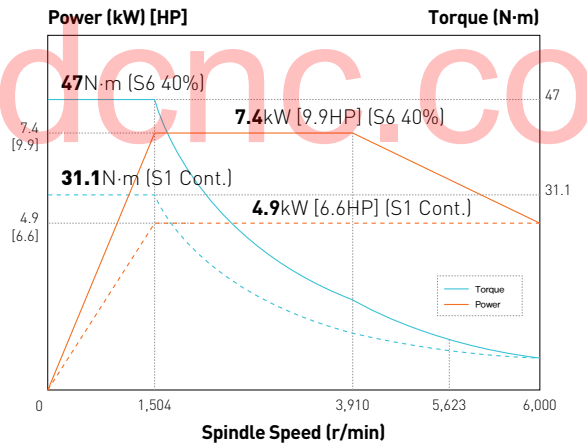

### Mill Turret 6,000 rpm

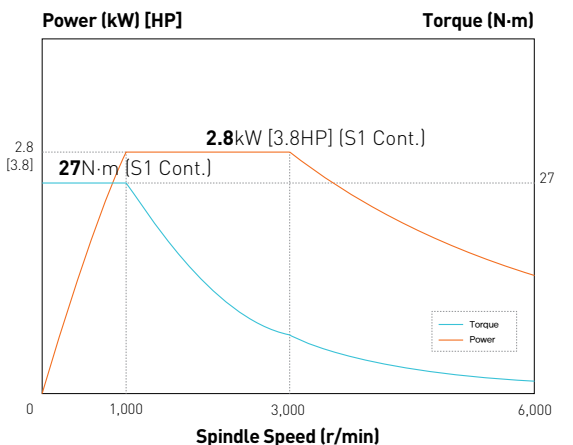

www.wardenc.com



# SPECIFICATIONS

## External Dimensions

unit : mm(in)

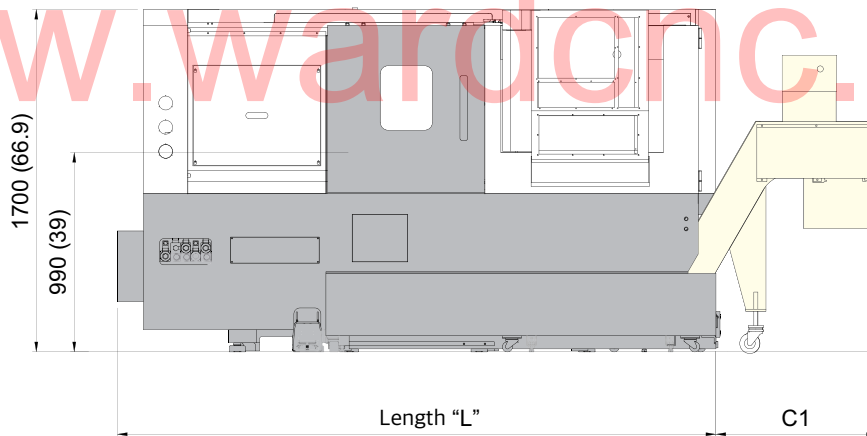
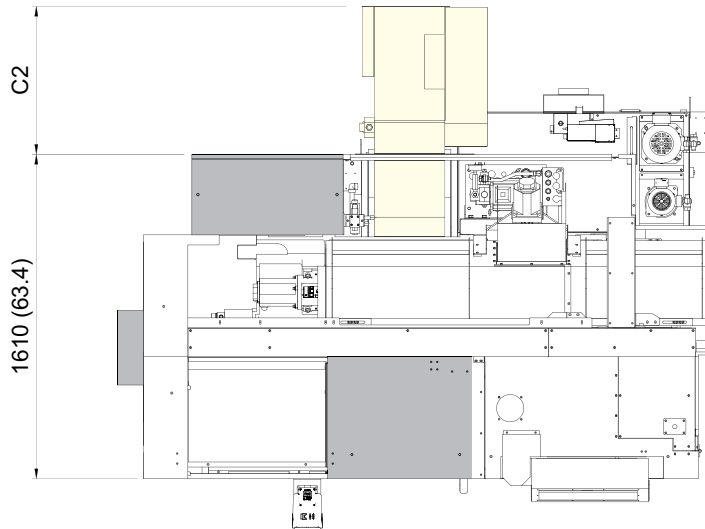

Chip Discharge Height

Opt. 1 : 860 (33.9), Opt. 2 : 1,200 (47.2)

ITEM	SE Series	Length "L"
2-axis	SE2200A	2,120 mm (83.5")
	SE2200	2,190 mm (86.2")
	SE2200LA/L/LC	2,970 mm (116.9")
MILL	SE2200MA	2,150 mm (84.6")
	SE2200M	2,220 mm (87.4")
	SE2200LMA/LM/LMC	2,970 mm (116.9")
SUB	SE2200LMSA/LMS/LMSC	2,970 mm (116.9")
ITEM	Chip Discharge Height	C1 / C2
Chip Conveyor	Option 1 : 860 mm (33.9")	930 mm (36.6")
	Option 2 : 1,200 mm (47.2")	1,130 mm (44.5")



# SPECIFICATIONS

## Interference

unit : mm(in)

SE2200MA/LMA  
SE2200M/LM  
SE2200LMC

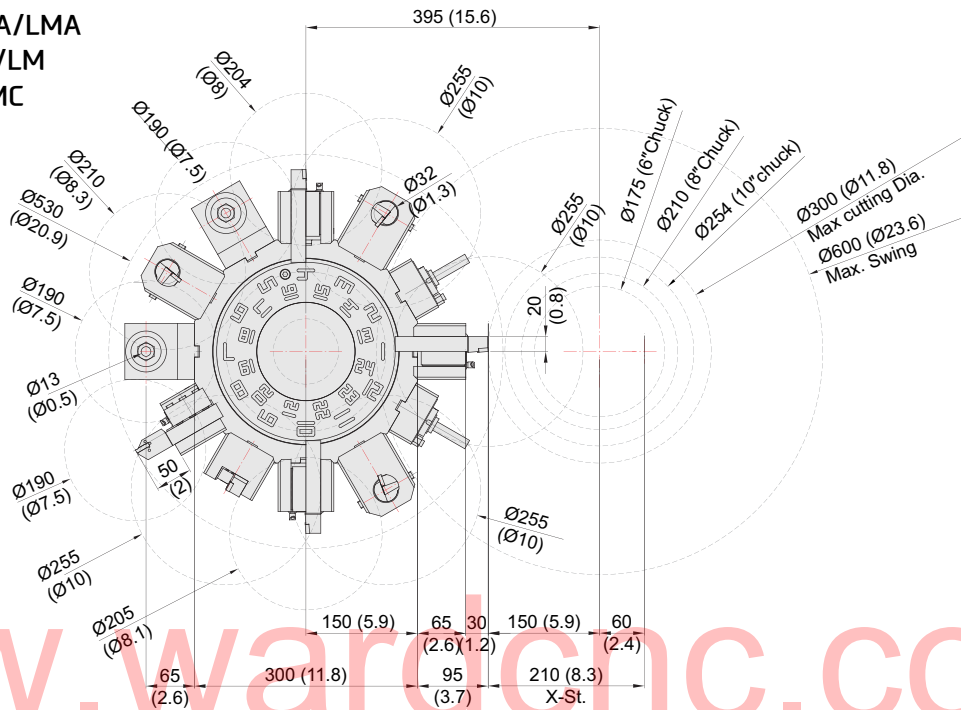

SE2200LMSA  
SE2200LMS  
SE2200LMSC

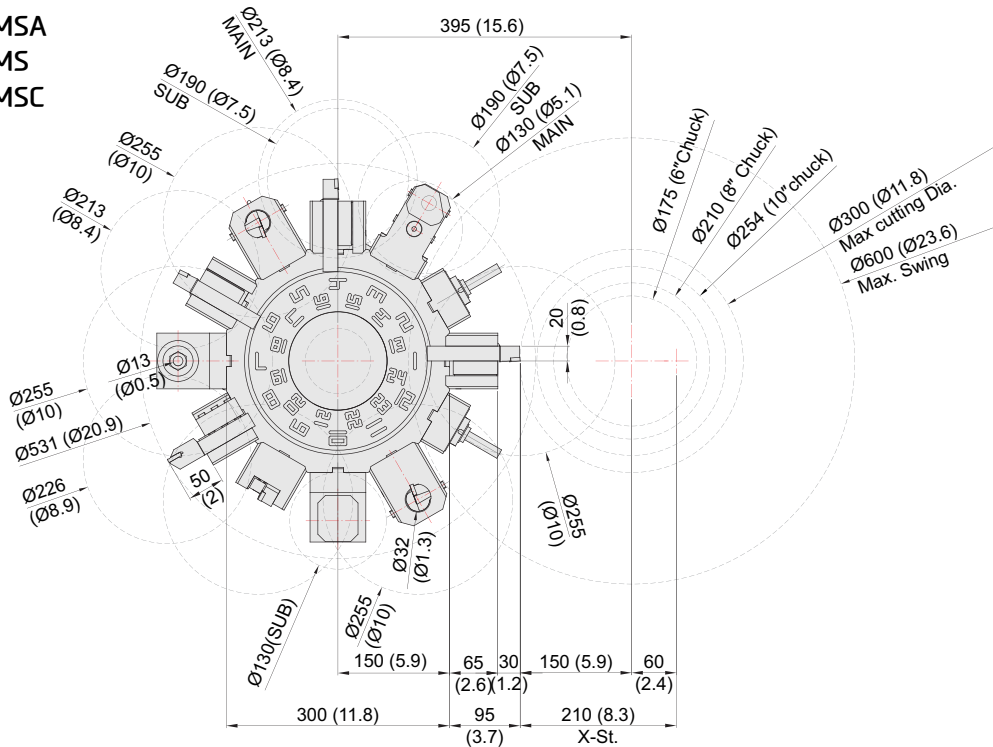

www.wardcnc.com

# SPECIFICATIONS

## Tooling System

unit : mm(in)

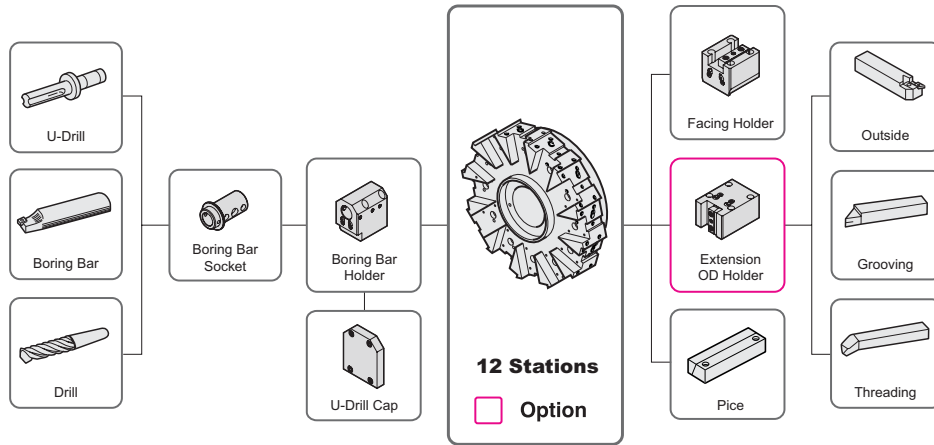

### Std. Turret Tooling Parts Detail (SE2200/A/LA/L/LC)

ITEM			6/8 inch	10 inch
Turning Holder	Clamper		6	5
	O.D Holder	Extension	-	1
	Facing Holder		1	1
Boring Holder	I.D Holder	Single (Ø40, Ø1 1/2")	5	5
	U-Drill Holder	Cap	1	1
Driven Holder	Straight Mill Holder	Standard	-	-
		TTC	-	-
	Angular Mill Holder	Standard	-	-
		TTC	-	-
Socket	Boring	Ø10 (Ø3/8")	1	1
		Ø12 (Ø1/2")	1	1
		Ø16 (Ø5/8")	1	1
		Ø20 (Ø3/4")	1	1
		Ø25 (Ø1")	1	1
		Ø32 (Ø1 1/4")	1	1
	Drill	MT 1	Opt.	Opt.
		MT 2	Opt.	Opt.
	ER Collet		-	-



# SPECIFICATIONS

## Tooling System

unit : mm(in)

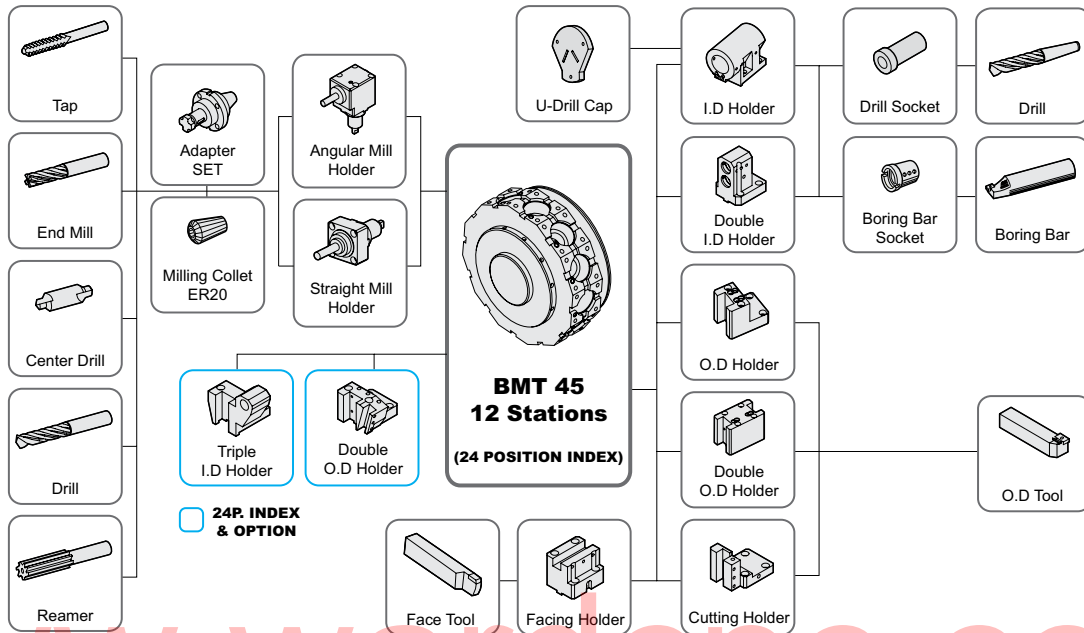

Mill Turret Tooling Parts Detail (SE2200MA/LMA/M/LM/LMC/LMSA/LMS/LMSC)

ITEM			"M" Type		"MS" Type	
			12 Stations	[24 Stations]	12 Stations	[24 Stations]
Turning Holder	O.D Holder	Right/Left	3	2	2	-
		Double	-	-	1	1
		Double (24P, Main)	-	1	-	1
		Double (24P, Sub)	-	-	-	1
	Facing Holder	1	1	1	1	
Cutting Holder	1	1	1	1		
Boring Holder	I.D Holder	Single	2	1	1	-
		Double	-	-	1	1
		Triple	-	1	-	1
U-Drill Holder	Cap	1	1	1	1	
Driven Holder	Straight Mill Holder	Standard	2	2	2	2
	Angular Mill Holder	Standard	2	2	2	2
Socket	Boring	Ø10 (Ø3/8")	1	1	1	1
		Ø12 (Ø1/2")	1	1	1	1
		Ø16 (Ø5/8")	1	1	1	1
		Ø20 (Ø3/4")	1	1	1	1
		Ø25 (Ø1")	1	1	1	1
		Ø10 (Ø3/8")	-	-	-	-
	Sub Boring	Ø8 (5/16")	-	1	1	1
		Ø10 (Ø3/8")	-	1	1	1
		Ø12 (1/2")	-	1	1	1
		Ø16 (5/8")	-	1	1	1
	Drill	MT 1	Opt.	Opt.	Opt.	Opt.
		MT 2	Opt.	Opt.	Opt.	Opt.
	ER Collet		1 Set	1 Set	1 Set	1 Set
	Adapter Set		Opt.	Opt.	Opt.	Opt.

Specifications are subject to change without notice for improvement.

# SPECIFICATIONS

Tooling Travel Range (SE2200A/LA | SE2200/L/LC)

unit : mm(in)

## O.D Tool

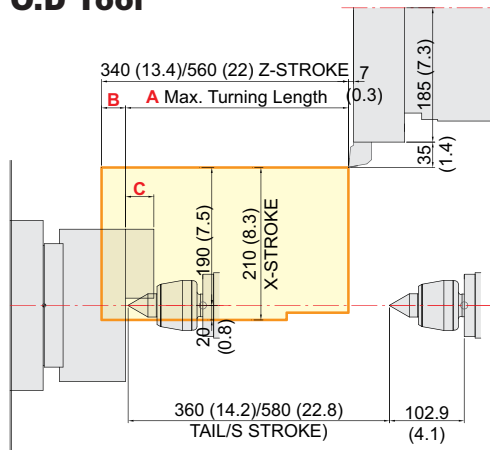

## Face Tool

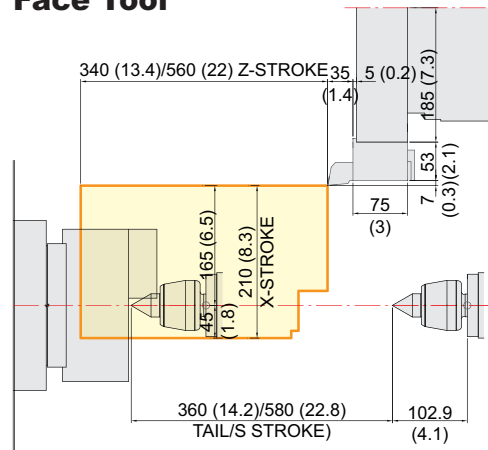

## I.D Tool

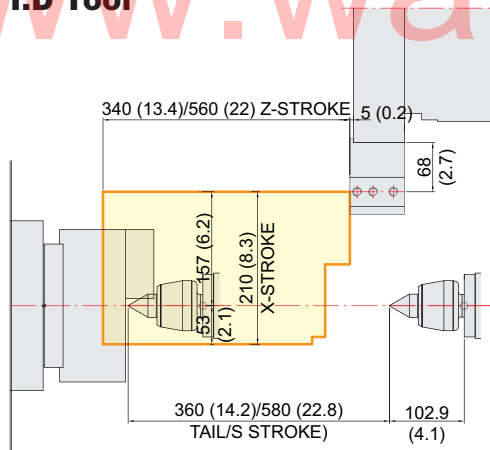

## SE2200LC Extension Tool

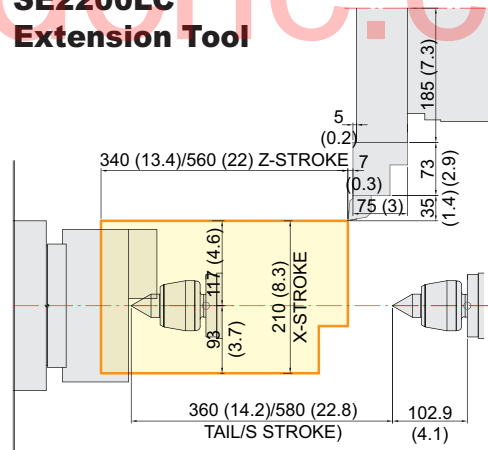

ITEM	A	B	C
SE2200A	340 (13.4)	-	32.5 (1.3)
SE2200LA	560 (22)	-	39 (1.5)
SE2200	307 (12.1)	33 (1.3)	39 (1.5)
SE2200L	558 (22)	2 (0.08)	43 (1.7)
SE2200LC	549 (21.6)	11 (0.43)	43 (1.7)

www.wardenc.com

# SPECIFICATIONS

Tooling Travel Range (SE2200MA/LMA | SE2200M/LM/LMC)

unit : mm(in)

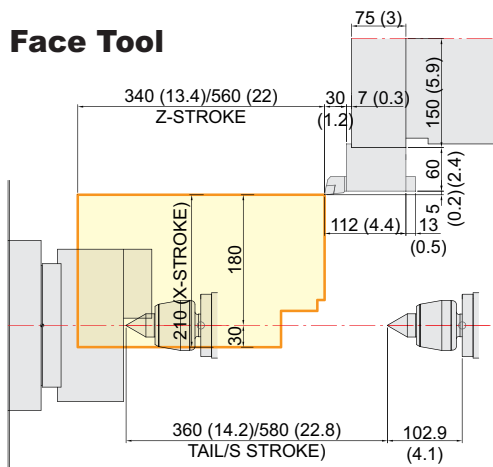
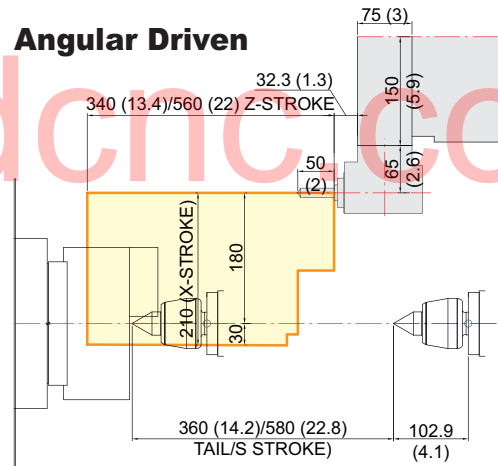
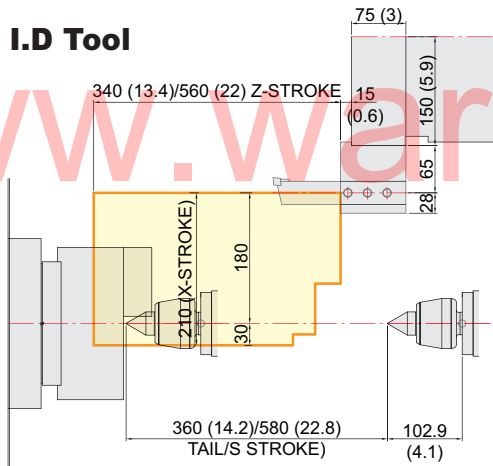
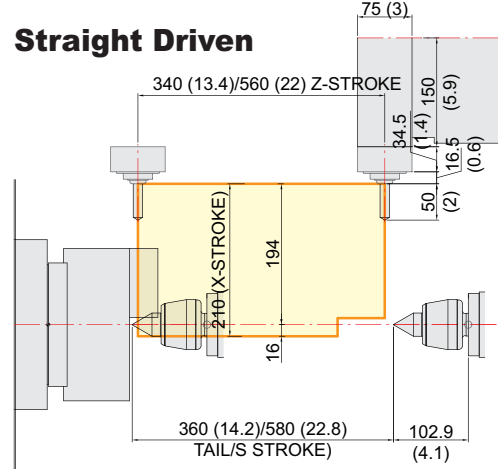
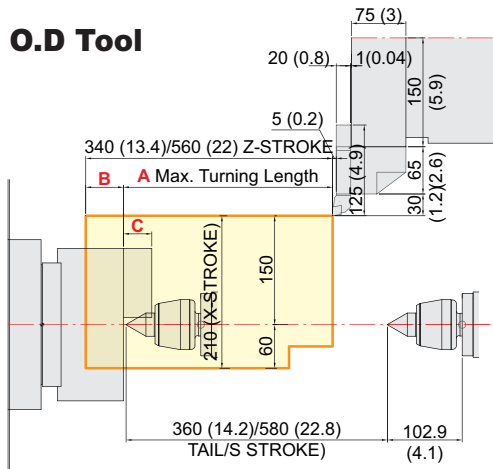

ITEM	A	B	C
SE2200MA	309 (12.2)	31 (1.2)	32.5 (1.3)
SE2200LMA	529 (20.8)		
SE2200M	288 (11.3)	52 (2)	39 (1.5)
SE2200LM	508 (20)		
SE2200LMC	499 (19.6)	61 (2.4)	43 (1.7)

# SPECIFICATIONS

Tooling Travel Range (SE2200LMSA/LMS/LMSC)

unit : mm(in)

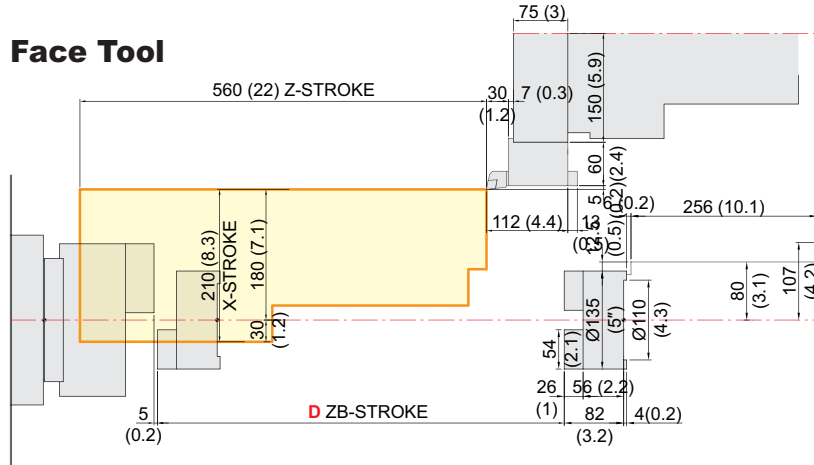
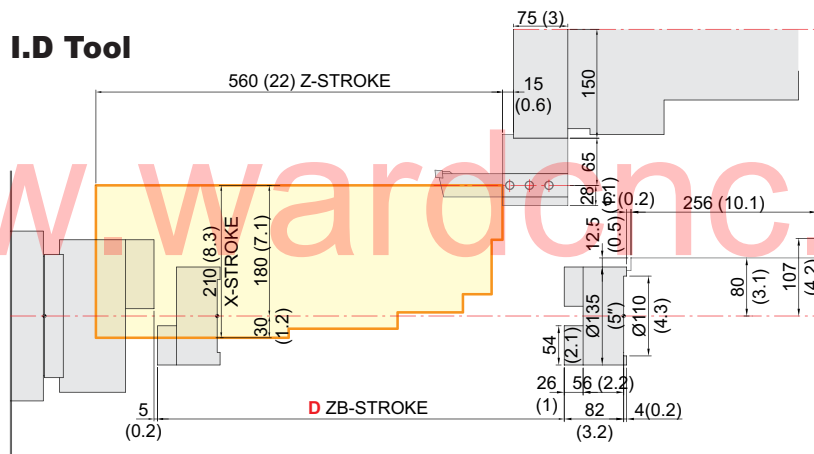
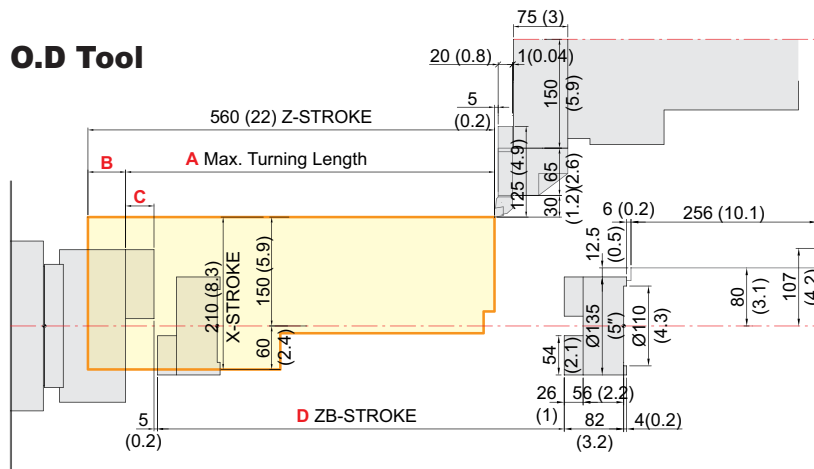

ITEM	A	B	C	D
SE2200LMSA	529 (20.8)	31 (1.2)	32.5 (1.3)	599.3 (23.6)
SE2200LMS	508 (20)	52 (2)	39 (1.5)	560 (22)
SE2200LMSC	499 (19.6)	61 (2.4)	43 (1.7)	547 (21.5)

# SPECIFICATIONS

Tooling Travel Range (SE2200LMSA/LMS/LMSC)

unit : mm(in)

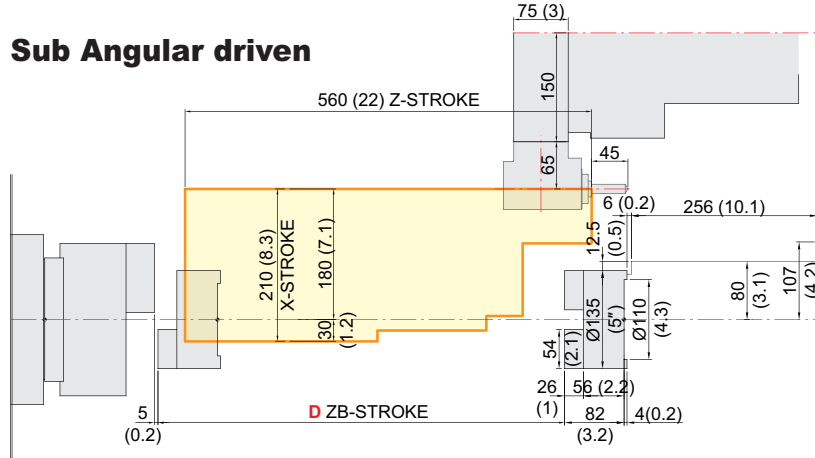
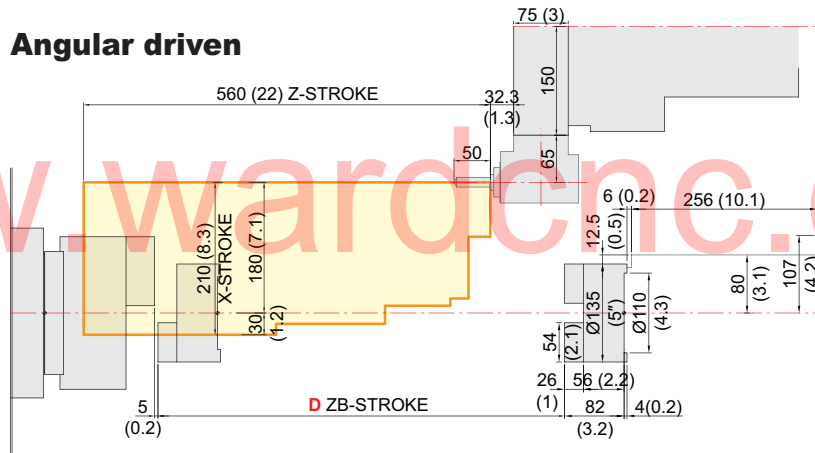
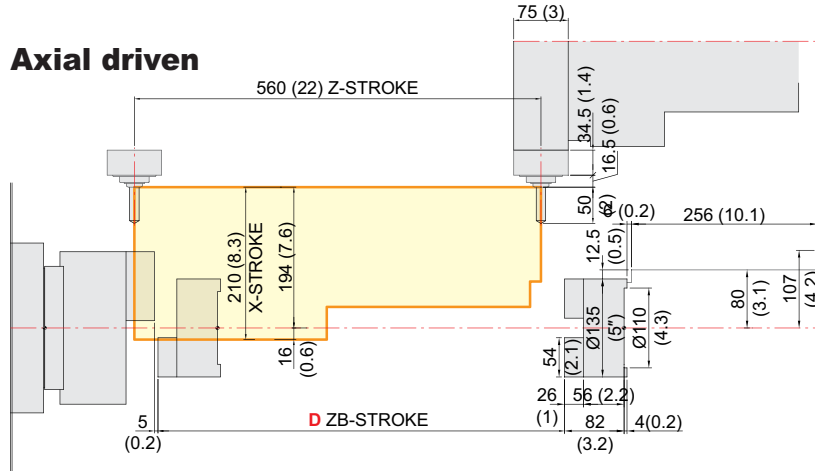

ITEM	A	B	C	D
SE2200LMSA	529 (20.8)	31 (1.2)	32.5 (1.3)	599.3 (23.6)
SE2200LMS	508 (20)	52 (2)	39 (1.5)	560 (22)
SE2200LMSC	499 (19.6)	61 (2.4)	43 (1.7)	547 (21.5)

www.wardcnc.com



# SPECIFICATIONS

## Specifications

[ ] : Option

ITEM		SE2200A	SE2200LA	SE2200MA	SE2200LMA	SE2200LMSA	
CAPACITY	Max. Swing	mm(in) Ø600 (Ø23.6")					
	Swing Over the Carriage	mm(in) Ø390 (Ø15.4")					
	Max. Turning Dia.	mm(in) Ø350 (Ø13.8")			Ø300 (Ø11.8")		
	Max. Turning Length	mm(in) 340 (13.4")	560 (22")	309 (12.2")	529 (20.8")		
	Bar Capacity	Main	mm(in) Ø51 (Ø2")				
Sub						mm(in) Ø32 (Ø1.3")	
SPINDLE	Chuck Size	Main	inch 6"				
		Sub	inch -				5"
	Spindle Bore	Main	mm Ø60 (Ø2.4")				
		Sub	mm -				Ø42 (Ø1.7")
	Spindle Speed (rpm)	Main	r/min 6,000				
		Sub	r/min -				6,000
	Motor (Max./Cont.)	Main	kW 15/11 (20/15) [13.5/9 (18/12)]				
		Sub	kW -				7.5/3.7 (10/5) [7.4/4.9 (93.9/6.6)]
	Max. Torque	Main	N·m 127 [114.5]				
		Sub	N·m -				63.6 [47]
Spindle Nose	Main	- A2-5					
	Sub	mm -				FLAT TYPE	
Spindle Type	Main	- BELT					
	Sub	- -				BELT	
C-axis Indexing	deg	- 0.001°					
FEED	Travel	X/Z	mm(in) 210/340 (8.3"/13.4")	210/560 (8.3"/22")	210/340 (8.3"/13.4")	210/560 (8.3"/22")	
		ZB	mm(in) -				599.3 (23.6")
	Rapid Traverse Rate	X/Z	m/min(ipm) 30/36 (1,181/1,417)				
		ZB	m/min(ipm) -				15 (591)
	Slide Type	-	ROLLER LM GUIDE				
TURRET	No. of Tools	ea 12"			12 [24]		
	Tool Size	O.D/I.D	mm(in) □ 25/Ø40 (□ 1"/Ø1 1/2")			□ 20/Ø32 (□ 3/4"/Ø1 1/4")	
	Indexing Time	sec/step 0.15					
LIVE TOOL	Milling Tool Speed (rpm)	r/min -			6,000		
	Motor (Max./Cont.)	kW(HP) -			2.75/1.85 (3.69/2.48) [Cont. : 2.8 (3.8)]		
	Max. Torque	N·m -			26.2 [Cont. : 27]		
	Collet Size	mm(in) -			ER20 / Ø13 (Ø0.5")		
	Type	- -			BMT45		
TAIL STOCK	Taper	- MT#4					
	Quill Dia.	mm(in) Ø56 (Ø2.2")					
	Travel	mm(in) 360 (14.2")	580 (22.8")	360 (14.2")	580 (22.8")	-	
TANK CAPACITY	Coolant Tank	ℓ (gal) 150 (39.6)	200 (52.8)	150 (39.6)	200 (52.8)		
	Lubricating Tank	ℓ (gal) 0.7 (0.18)					
POWER SUPPLY	Electric Power Supply	kVA 18				23	
	Thickness of Power Cable	Sq Over 16					
	Voltage	V/Hz 220V, 50/60Hz					
MACHINE	Floor Space (L×W)	mm(in) 2,120×1,610 (83.5"×63.4")	2,970×1,610 (116.9"×63.4")	2,150×1,610 (84.6"×63.4")	2,970×1,610 (116.9"×63.4")		
	Height	mm(in) 1,700 (66.9")					
	Weight	kg(lb) 3,100 (6,834)	3,500 (7,716)	3,150 (6,945)	3,550 (7,826)	3,650 (8,047)	
CNC	Controller	- HYUNDAI WIA FANUC - SMART PLUS [HYUNDAI-iTROL]					

# CONTROLLER

## Specifications

[ ] : Option

ITEM			SE2200	SE2200L	SE2200M	SE2200LM	SE2200LMS	
CAPACITY	Max. Swing	mm(in)	Ø600 (Ø23.6")					
	Swing Over the Carriage	mm(in)	Ø390 (Ø15.4")					
	Max. Turning Dia.	mm(in)	Ø350 (Ø13.8")		Ø300 (Ø11.8")			
	Max. Turning Length	mm(in)	307 (12.1")	558 (22")	288 (11.3")	508 (20")		
	Bar Capacity	Main	mm(in)	Ø65 (Ø2.6")				
Sub		mm(in)	-				Ø32 (Ø1.3")	
SPINDLE	Chuck Size	Main	inch		8"			
		Sub	inch		-		5"	
	Spindle Bore	Main	mm		Ø75 (Ø3")			
		Sub	mm		-		Ø42 (Ø1.7")	
	Spindle Speed (rpm)	Main	r/min		4,500			
		Sub	r/min		-		6,000	
	Motor (Max./Cont.)	Main	kW		15/11 (20/15) [13.5/9 (18/12)]			
		Sub	kW		-		7.5/3.7 (10/5) [7.4/4.9 (93.9/6.6)]	
	Max. Torque	Main	N·m		167 [150.3]			
		Sub	N·m		-		63.6 [47]	
	Spindle Nose	Main	-		A2-6			
Sub		mm		-		FLAT TYPE		
Spindle Type	Main	-		BELT				
	Sub	-		-		BELT		
C-axis Indexing		deg		-		0.001°		
FEED	Travel	X/Y	mm(in)		210/340 (8.3"/13.4")	210/560 (8.3"/22")	210/340 (8.3"/13.4") 210/560 (8.3"/22")	
		Z/B	mm(in)		-		560 (22")	
	Rapid Traverse Rate	X/Y	m/min(ipm)		30/36 (1,181/1,417)			
		Z/B	m/min(ipm)		-		15 (591)	
	Slide Type	-		ROLLER LM GUIDE				
TURRET	No. of Tools	ea		12		12 [24]		
	Tool Size	O.D./I.D	mm(in)		□ 25/Ø40 (□ 1"/Ø1 1/2")		□ 20/Ø32 (□ 3/4"/Ø1 1/4")	
	Indexing Time	sec/step		0.15				
LIVE TOOL	Milling Tool Speed (rpm)	r/min		-		6,000		
	Motor (Max./Cont.)	kW(HP)		-		2.75/1.85 (3.69/2.48) [Cont. : 2.8 (3.8)]		
	Max. Torque	N·m		-		26.2 [Cont. : 27]		
	Collet Size	mm(in)		-		ER20 / Ø13 (Ø0.5")		
	Type	-		-		BMT45		
TAIL STOCK	Taper	-		MT#4			-	
	Quill Dia.	mm(in)		Ø56 (Ø2.2")			-	
	Travel	mm(in)		360 (14.2")	580 (22.8")	360 (14.2")	580 (22.8")	
TANK CAPACITY	Coolant Tank	ℓ (gal)		150 (39.6)	200 (52.8)	150 (39.6)	200 (52.8)	
	Lubricating Tank	ℓ (gal)		0.7 (0.18)				
POWER SUPPLY	Electric Power Supply	kVA		18			23	
	Thickness of Power Cable	Sq		Over 16				
	Voltage	V/Hz		220V, 50/60Hz				
MACHINE	Floor Space (L×W)	mm(in)		2,190×1,610 (86.2"×63.4")	2,970×1,610 (116.9"×63.4")	2,220×1,610 (87.4"×63.4")	2,970×1,610 (116.9"×63.4")	
	Height	mm(in)		1,700 (66.9")				
	Weight	kg(lb)		3,200 (7,055)	3,600 (7,937)	3,250 (7,165)	3,650 (8,047) 3,750 (8,267)	
CNC	Controller	-		HYUNDAI WIA FANUC - SMART PLUS [HYUNDAI-ITROL]				

Specifications are subject to change without notice for improvement.

# SPECIFICATIONS

## Specifications

[ ] : Option

ITEM		SE2200LC	SE2200LMC	SE2200LMSC
CAPACITY	Max. Swing	mm(in)	Ø600 (Ø23.6")	
	Swing Over the Carriage	mm(in)	Ø390 (Ø15.4")	
	Max. Turning Dia.	mm(in)	Ø350 (Ø13.8")	Ø300 (Ø11.8")
	Max. Turning Length	mm(in)	549 (21.6")	499 (19.6")
	Bar Capacity	Main	mm(in)	Ø81 (Ø3.2")
Sub		mm(in)	-	Ø32 (Ø1.3")
SPINDLE	Chuck Size	Main	10"	
		Sub	-	5"
	Spindle Bore	Main	Ø91 (Ø3.6")	
		Sub	-	Ø42 (Ø1.7")
	Spindle Speed (rpm)	Main	3,500	
		Sub	-	6,000
	Motor (Max./Cont.)	Main	15/11 (20/15) [13.5/9 (18/12)]	
		Sub	-	7.5/3.7 (10/5) [7.4/4.9 (93.9/6.6)]
	Max. Torque	Main	270 [197.6]	
		Sub	-	63.6 [47]
Spindle Nose	Main	A2-8		
	Sub	-	FLAT TYPE	
Spindle Type	Main	BELT		
	Sub	-	BELT	
C-axis Indexing	deg	-	0.001°	
FEED	Travel	X/Y	210/560 (8.3"/22")	
		Z/ZB	-	547 (21.5")
	Rapid Traverse Rate	X/Y	30/36 (1,181/1,417)	
		Z/ZB	-	15 (591)
Slide Type	-	ROLLER LM GUIDE		
TURRET	No. of Tools	ea	12	12 [24]
	Tool Size	O.D./I.D mm(in)	□ 25/Ø40 (□ 1"/Ø1 1/2")	□ 20/Ø32 (□ 3/4"/Ø1 1/4")
	Indexing Time	sec/step	0.15	
LIVE TOOL	Milling Tool Speed (rpm)	r/min	-	6,000
	Motor (Max./Cont.)	kw(HP)	-	2.75/1.85 (3.69/2.48) [Cont. : 2.8 (3.8)]
	Max. Torque	N·m	-	26.2 [Cont. : 27]
	Collet Size	mm(in)	-	ER20 / Ø13 (Ø0.5")
	Type	-	-	BMT45
TAIL STOCK	Taper	-	MT#4	
	Quill Dia.	mm(in)	Ø56 (Ø2.2")	
	Travel	mm(in)	580 (22.8")	
TANK CAPACITY	Coolant Tank	ℓ (gal)	200 (52.8)	
	Lubricating Tank	ℓ (gal)	0.7 (0.18)	
POWER SUPPLY	Electric Power Supply	kVA	18	
	Thickness of Power Cable	sq	Over 16	
	Voltage	V/Hz	220V, 50/60Hz	
MACHINE	Floor Space (L×W)	mm(in)	2,970×1,610 (116.9"×63.4")	
	Height	mm(in)	1,700 (66.9")	
	Weight	kg(lb)	3,700 (8,157)	3,750 (8,267)
CNC	Controller	-	HYUNDAI WIA FANUC i Series - Smart Plus [HYUNDAI-iTROL]	

# CONTROLLER

## HYUNDAI WIA FANUC i Series – Smart Plus

[ ] : Option

Controlled axis / Display / Accuracy Compensation	
Control axes	2 axes (X, Z) / 3 axes (X, Z, C) / 4 axes (X,Z,Y,C) 5 axes (X, Z, B, C, A) / 6 axes (X, Z, Y, B, C, A) 7 axes (X1/Z1, X2/Z2, B2, C1/C2)
Simultaneously controlled axes	2 axes [Max. 4 axes]
Designation of spindle axes	3 axes [Max. 4 axes]
Least setting Unit	X, Z, Y, B axes : 0.001 mm (0.0001 inch) C, A axes : 0.001 deg
Least input increment	X, Z, Y, B axes : 0.001 mm (0.0001 inch) C, A axes : 0.001 deg
Inch / Metric conversion	G20 / G21
High response vector control	
Interlock	All axes / Each axis
Machine lock	All axes
Backlash compensation	± 0~9999 pulses (exc. Rapid traverse / Cutting feed)
Position switch	
LCD / MDI	15 inch LCD unit (with Touch Panel)
Feedback	Absolute motor feedback
Stored stroke check 1	Over travel
Stored stroke check 2, 3	
PMC axis control	
Operation	
Automatic operation (Memory)	
MDI operation	
DNC operation	Needed DNC software / CF card
Program restart	
Wrong operation prevention	
Program check function	Dry run
Single block	
Search function	Program Number / Sequence Number
Interpolation functions	
Nano interpolation	
Positioning	G00
Linear interpolation	G01
Circular interpolation	G02, G03
Exact stop mode	Single : G09, Continuous : G61
Dwell	G04, 0 ~ 9999.9999 sec
Skip	G31
Reference position return	1st reference : G28, 2nd reference : G30 Ref. position check : G27
Thread synchronous cutting	G33
Thread cutting retract	
Variable lead thread cutting	
Multi / Continuous threading	
Feed function / Acc. & Dec. control	
Manual feed	Rapid traverse Jog : 0~2,000 mm/min (79 ipm) Manual handle : x1, x10, x100 pulses Reference position return
Cutting Feed command	Direct input F code
Feedrate override	0 ~ 200% (10% Unit)
Rapid traverse override	1%, F25%, 50%, 100%
Override cancel	
Feed per minute	G98
Feed per revolution	G99
Look-ahead block	1 block
Program input	
Tape Code	EIA / ISO
Optional block skip	1 ea
Absolute / Incremental program	G90 / G91
Program stop / end	M00, M01 / M02, M30
Maximum command unit	± 999,999.999 mm (± 99,999.9999 inch)
Plane selection	X-Y : G17 / Z-X : G18 / Y-Z : G19
Workpiece coordinate system	G52, G53, 6 pairs (G54 ~ G59)
Manual absolute	Fixed ON
Programmable data input	G10
Sub program call	10 folds nested
Custom macro	#100 ~ #199, #500 ~ #999
G code system	A, B/C
Programmable mirror image	G51.1, G50.1
G code preventing buffering	G4.1
Direct drawing dimension program	Including Chamfering / Corner R
Conversational Program	SmartGuide-i

Program input	
Multiple repetitive cycles	I, II
Canned cycle for turning	
Auxiliary function / Spindle speed function	
Auxiliary function	M & 4 digit
Level-up M Code	High speed / Multi / Bypass M code
Spindle speed function	S & 5 digit, Binary output
Spindle override	0% ~ 150% (10% Unit)
Multi position spindle orientation	M19 (S##)
FSSB Rigid tapping	
Constant surface speed control	G96, G97
Tool function / Tool compensation	
Tool function	T & 2 digit + Offset 2 digit
Tool life management	
Tool offset pairs	128 pairs
Tool nose radius compensation	G40, G41, G42
Geometry / Wear compensation	
Direct input of offset measured B	
Editing function	
Part program storage size	5,120m (2MB)
No. of registerable programs	1,000 ea
Program protect	
Background editing	
Extended part program editing	Copy, move and change of NC program
Memory card program edit	
Data input / output & Interface	
I/O interface	CF card, USB memory Embedded Ethernet interface
Screen hard copy	
External message	
External key input	
External workpiece number search	
Automatic data backup	
Setting, display and diagnosis	
Self-diagnosis function	
History display & Operation	Alarm & Operator message & Operation
Run hour / Parts count display	
Maintenance information	
Actual cutting feedrate display	
Display of spindle speed / T code	
Graphic display	
Operating monitor screen	Spindle / Servo load etc.
Power consumption monitoring	Spindle & Servo
Spindle / Servo setting screen	
Multi language display	Support 24 languages
Display language switching	Selection of 5 optional Languages
LCD Screen Saver	Screen saver
Unexpected disturbance torque	BST (Back spin torque limit)
Function for machine type	
Cs contour control (C & A axes)	Mill, MS, Y, SY, LF-Mill, TTMS, TTSY
Polar coordinate interpolation	Mill, MS, Y, SY, LF-Mill, TTMS, TTSY
Cylindrical interpolation	Mill, MS, Y, SY, LF-Mill, TTMS, TTSY
Polygon turning (2 Spindles)	Mill, MS, Y, SY, LF-Mill, TTMS, TTSY
Canned cycle for drilling	Mill, MS, Y, SY, LF-Mill, TTMS, TTSY
Spindle orientation expansion	MS, SY, TTS, TTMS, TTSY
Spindle synchronous control	MS, SY, TTS, TTMS, TTSY
Torque control	MS, SY, TTS, TTMS, TTSY
Y axis offset	Y, SY, TTSY
Arbitrary angular control	Y, SY, TTSY
Composite / Superimposed control	MS, SY, TTS, TTMS, TTSY
Balance cutting	TTS, TTMS, TTSY
Option	
Additional optional block skip	9 ea
Fast ethernet	Needed option board
Data server	Needed option board
Protection of data at 8 levels	
Tool offset pairs	200 pairs
Helical interpolation	
Optional block skip	40 ea, 200 ea (AICC II)

Figures in inch are converted from metric values.

The FANUC controller specifications are subject to change based on the policy of company CNC supplying.

# 06 GLOBAL NETWORK

HYUNDAI WIA opens a new era in the machinery industry.  
Reborn as a global leader.





# GLOBAL NETWORK



## HEADQUARTER

### Changwon Technical Center/R&D Center/Factory

153, Jeongdong-ro, Seongsan-gu, Changwon-si, Gyeongsangnam-do, Korea  
(Zip Code : 51533) TEL : +82 55 280 9114 FAX : +82 55 282 9680

### Uiwang Technical Center/R&D Center

37, Cheoldobangmulgwan-ro, Uiwang-si, Gyeonggi-do, Korea  
(Zip Code : 16082) TEL : +82 31 596 8209 FAX : +82 55 210 9804

## OVERSEAS OFFICES

### EUROPE

#### HYUNDAI WIA Machine Tools Europe / Europe R&D Center

Alexander-Fleming-Ring 57, 65428 Rüsselsheim Germany  
TEL : +49-0-6142-9256-0

#### HYUNDAI WIA Russia

Russia, 197374, St. Petersburg, Torfyanaya doroga 7,  
Business center <Gulliver-2>, Office No. 825

### ASIA

#### Beijing HYUNDAI WIA

No.9, West of Shunxi South Road, Renhe Town, Shunyi District, Beijing, China  
TEL : +86-10-6049-6373

#### Beijing Branch Office

1401, Zhonghangji Plaza B, No. 15 Ronghua South Road, BDA Dist, Daxing Dist,  
Beijing, China, 100176  
TEL : +86-10-8453-9850

#### Shandong HYUNDAI WIA

Company No.188 Shanghai Road, Rizhao City, Shandong Province, China  
TEL : +86-633-229-9021

#### Chengdu Branch Office

No.508 Room, B Block, AFC Plaza, No.88 Jiaozui Road, High-tech Zone, Chengdu,  
China  
TEL : +86-28-8666-4470

#### Jiangsu HYUNDAI WIA

Company No.6 Fenghuang Road, Fenghuang Town, Zhangjiagang City, Jiangsu  
Province, China  
TEL : +86-512-5842-2500

#### Qingdao Branch Office

Room 1207, Caifu Building, 182-6 Haier Middle Road, Qingdao, China  
TEL : +86-532-8667-9334

#### HYUNDAI WIA Machine Tools China

1-3F, Bldg6, No.1535 Hongmei Road, Xuhui District, Shanghai, China  
TEL : +86-21-6427-9885

#### India Branch Office

#4/169, 1st Floor, LOTTE BLDG, Rajiv Gandhi Salai, (OMR), Kandanchavadi, Chennai  
- 600096, Tamilnadu, India  
TEL : +91-76-0490-1618

#### HYUNDAI WIA India

48, Sur.No78-80, Kandamangalam Village, Sengadu Post, Sriperumbudur Taluk,  
Kancheepuram, Tamil Nadu-602 105, India  
TEL : +91-44-2715-9302

#### Vietnam Branch Office

Flat number 05, Service and Trade Center of Viet Huong Industrial Zone, Highway  
13, Thuan Giao, Thuan An, Binh Duong, Vietnam  
TEL : +84-3-5399-5099

### AMERICA

#### HYUNDAI WIA Machine America corp.

450 Commerce Blvd, Carlstadt, NJ 07072, USA  
TEL : +1-201-987-7298

#### HYUNDAI WIA America R&D Center

39205 Country Club Drive Suite C-9, Farmington Hills, MI 48331, USA  
TEL : +1-248-324-1057

#### HYUNDAI WIA Mexico

Carretera a Pesquería-Los Ramones KMS 13 al 15 Interior 18 Localidad "La Arena"  
Pesquería C.P.66679, Nuevo León México  
TEL : +52-1-81-1646-5208

HYUNDAI  
**WIA**  
www.wardcnc.com



HYUNDAI WIA MT

<https://www.youtube.com/HYUNDAIWIAMT>

**EXPERIENCE THE NEW TECHNOLOGY**

With its top-quality HYUNDAI WIA machine tool creates a new and better world.



<http://machine.hyundai-wia.com>

HYUNDAI WIA Machine Tools  
Global Links

2020-08 001.002 ENG