

# L600/700/800

HYUNDAI WIA CNC Turning Center

[www.wardcnc.com](http://www.wardcnc.com)



# Technical Leader

The CNC Turning Center L600,700,800 Series designed by Hyundai WIA with years of expertise and the latest technology, is a Turning Center that maximizes productivity and performance.

ITEM	Chuck (Option)					Bed		Turret
	18"	21"	24"	32"	34"	Standard	Long	Turn Mill
L600A	●	●				●		
L600LA	●	●					●	
L600MA	●	●				●		●
L600LMA	●	●					●	●
L700A			●			●		
L700LA			●				●	
L700MA			●			●		●
L700LMA			●				●	●
L800A				●		●		
L800LA				●			●	
L800MA				●		●		●
L800LMA				●			●	●
L800D					●	●		
L800LD					●		●	
L800MD					●	●		●
L800LMD					●		●	●

www.wardcnc.com

## Load Capacity

◆ The labelled weight excludes the weight of the chuck

ITEM	Max. Work {kgf(lbf)}		Std. Work {kgf(lbf)}	
	Chuck Work	Center Work	Chuck Work	Center Work
L600A/MA	456 (1,005)	1,261 (2,780)	202 (445)	709 (1,563)
L600LA/MA	456 (1,005)	2,484 (5,476)	202 (445)	1,397 (3,080)
L700A/MA	695 (1,532)	1,671 (3,684)	309 (681)	940 (2,072)
L700LA/MA	695 (1,532)	3,291 (7,255)	309 (681)	1,851 (4,081)
L800A/MA	1,567 (3,455)	2,873 (6,334)	696 (1,534)	1,616 (3,563)
L800LA/MA	1,567 (3,455)	5,660 (12,478)	696 (1,534)	3,184 (7,020)

Heavy Duty, Large Work Capacity,  
CNC Turning Center

# L600/700/800

- Sturdiness secured through box guideways on all axes
- One piece structure for high accuracy and rigidity
- Pretensioned double anchored method provides high precision
- Heat deformation in the main spindle is minimized
- Gear box type main spindle (L600/700 Series : 3 step/ L800 Series : 2 step)
- Big Bore Spindle with a maximum spindle bore of  $\text{Ø}375$  ( $\text{Ø}14.8''$ ) (L800D Series)
- Structure designed for machining long shafts and pipes with maximum turning length of 3,250mm (128'') (Long Bed Type)



The image shows a large industrial CNC turning center. The top portion of the image is a close-up of the machine's structure, featuring large, dark grey metal panels with visible weld lines and rivets. A teal-colored rectangular box is overlaid on the left side of this section, containing white text. The bottom portion of the image shows a large, polished metal workpiece being machined. The workpiece has a complex, multi-faceted design with several cylindrical sections of varying diameters and lengths. The lighting is bright, highlighting the metallic surfaces and the precision of the machining process.

## The Next Generation CNC Turning Center

The L600/700/800 Series, specialized in machining large products, features box guideways in all axes and gear driven main spindle. The series demonstrates unsurpassed performance in heavy duty cutting.

[www.wardcnc.com](http://www.wardcnc.com)

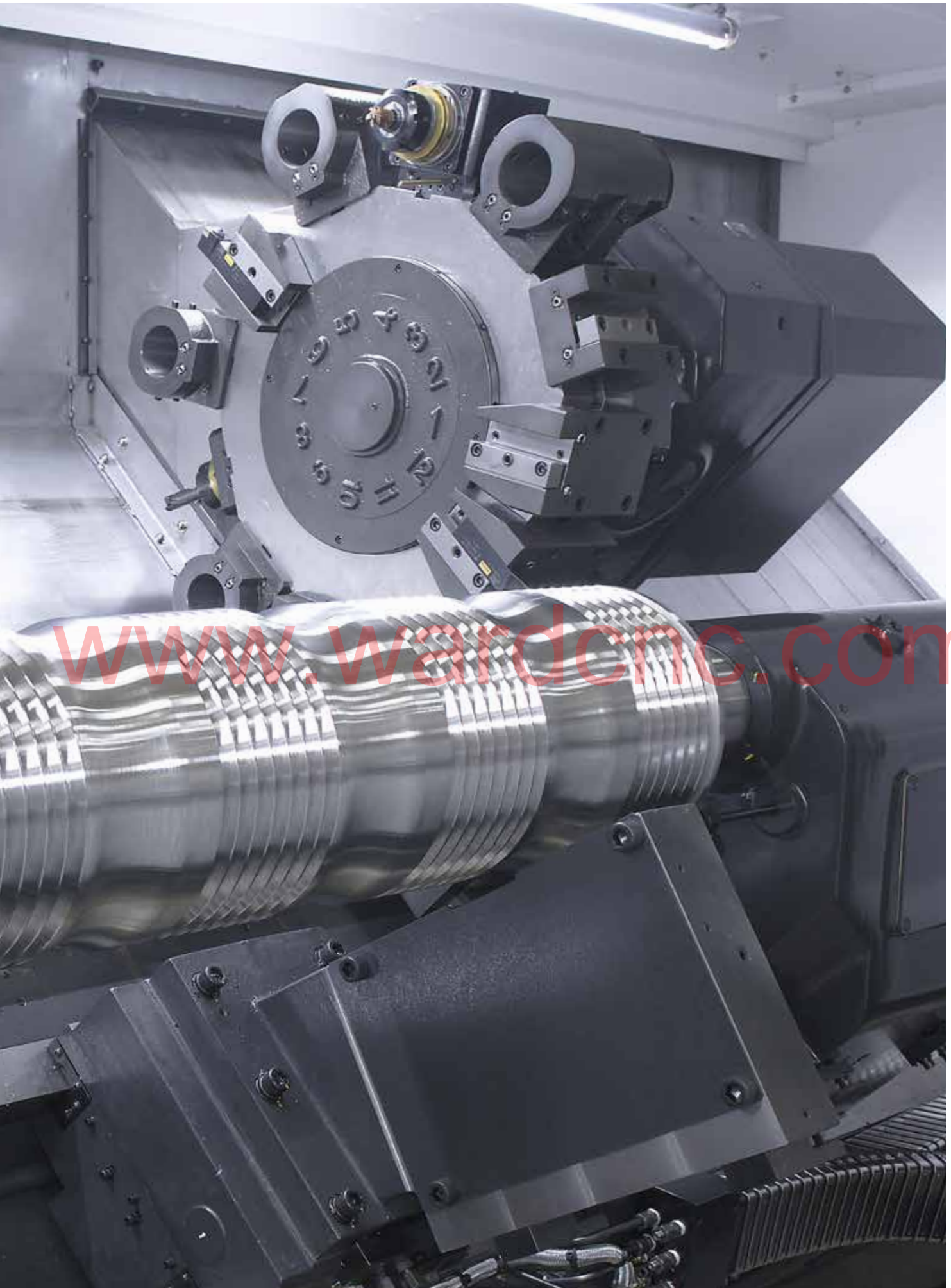

[www.wardcm.com](http://www.wardcm.com)

HYUNDAI WIA  
MACHINE TOOL

**L600/700/800 SERIES**  
HEAVY DUTY TURNING CENTER

04  
+  
05

# 01

L600/700/800

## Basic Features

High Rigid Bed & Structure for Heavy Duty Turning Center

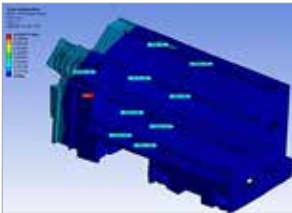

01

### High Precision, High Rigidity One-Piece Structure

The L600/700/800 series features a 45° slant bed design which is developed through finite element analysis (FEA) to effectively absorb vibration and minimize heat generation. The structure ensures stability which enables powerful and precise cutting.

### Box Guideway

For all the axes of L600/700/800 series, box guideways are applied to provide unsurpassed long term rigidity and accuracy, even during heavy duty cutting.

02

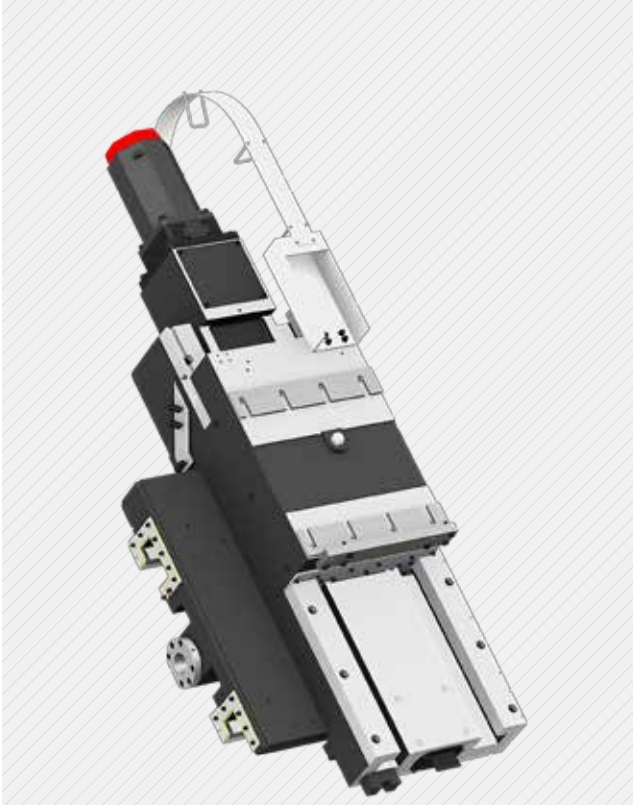

### Ball Screw

Travel is stabilized by fixing both ends of the ball screw with double anchored method. In particular, a large diameter ball screw with proper preload reinforces sturdiness and resistance to thermal displacement.

03

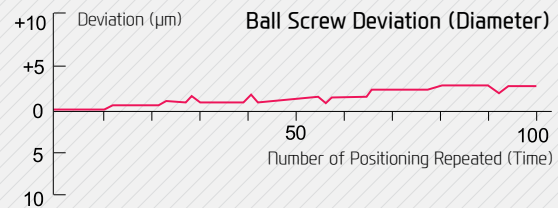

### Mill Turret (BMT)

The BMT turret, with 4 screws solidly fixing the holder, shows outstanding performance in powerful cutting and is capable of machining complex products by using milling tools.

04



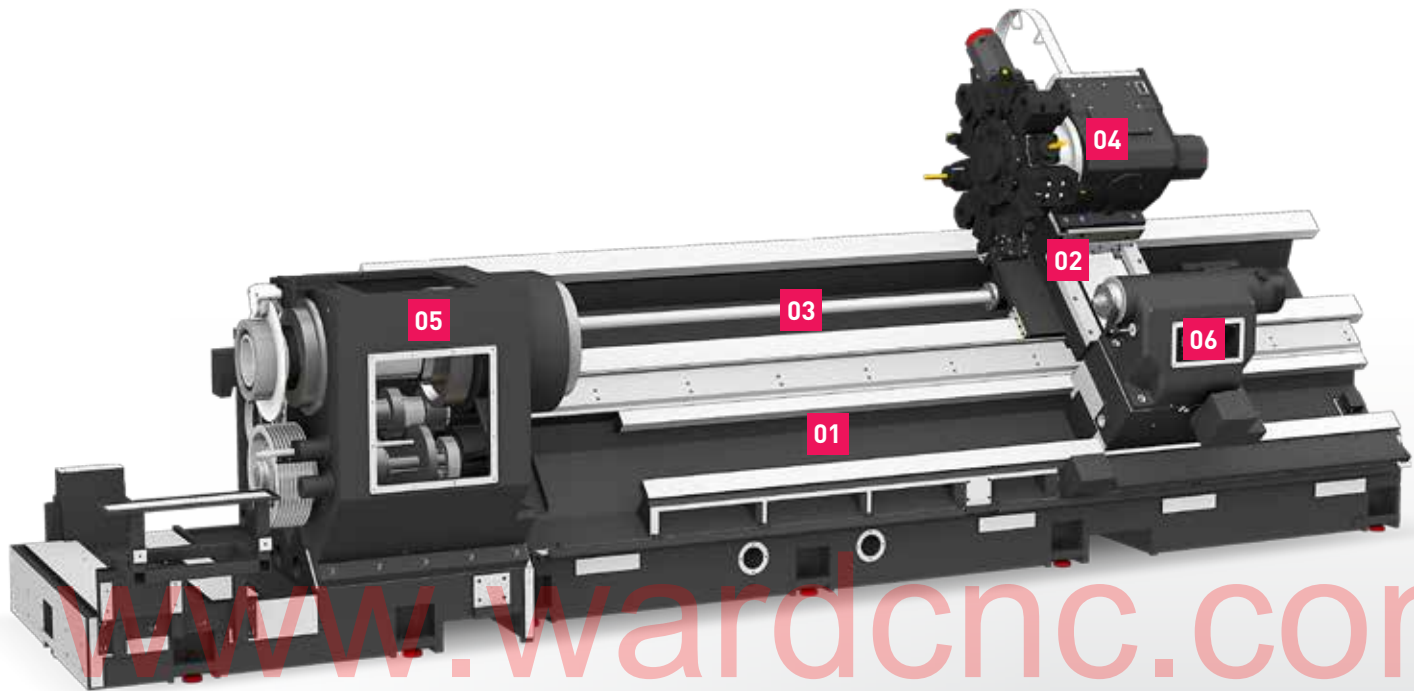

## Powerful Cutting Capability & Large Working Area

### Travel (X/Z axis)

L600A/MA | 700A/MA | 800A/MA/D : 500/1,680 mm (19.7"/66.1")

L600LA/LMA | 700LA/LMA | 800LA/LMA : 500/3,280 mm (19.7"/129.1")

### Main Spindle

The main spindle has become sturdier by enlarging its diameter and thickness. Its sturdiness has been further reinforced by the design combining highly accurate angular ball bearings and roller bearings.



05

### Built-in Tail Stock

The large built-in type tailstock makes it possible to maintain stable machining and accuracy even during a powerful heavy cutting operation. (L800D Series : Option)



06

02  
L600/700/800

## High-Precision Spindle

Long Lasting High Accuracy & Excellent Performance  
CNC Turning Center

### Main Spindle

- To accomplish stability even during heavy duty cutting, the spindle is designed with a combination of P4 level double cylindrical roller bearings and angular bearings.
- The spindle and the headstock are designed to maintain long time high accuracy.
- An advanced double locking device is applied which separates the spindle bearing and pulley. It prevents the release of spindle bearing pretension during heavy duty cutting, chuck cylinder operation, and belt pulley tension.

### C-Axis Control

The "M" type machines of L600/700/800 series where milling is possible, provide C-axis control of 0.001°. This enables various types of machining.

### Spindle Gear Box

Gear shift of spindle provide stability and high torque during low speed.

L600/700 Series : 3 Step Gear

L800 Series : 2 Step Gear

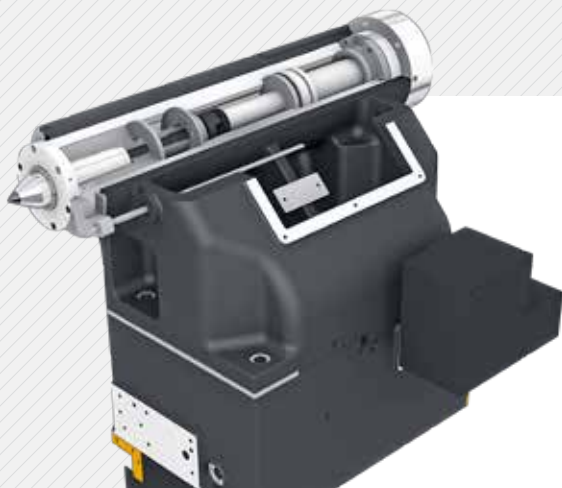

### MT#6 Built-In Tail Stock

The built-in type tailstock ensures high accuracy even during heavy duty cutting. It can be controlled manually or automatically by program. (L800D Series : Option)

Quill Dia. :  $\varnothing 160$  ( $\varnothing 6.3$ ") Quill Travel : 132.5 mm (5.2")

Travel : 1,580 mm (62.2"), L Type : 3,180 mm (125.2")



## Spindle Output/Torque Diagram

Continuously variable transmission is possible due to the use of a AC conversion motor and the function of controlling the spindle at a certain speed is provided as standard.

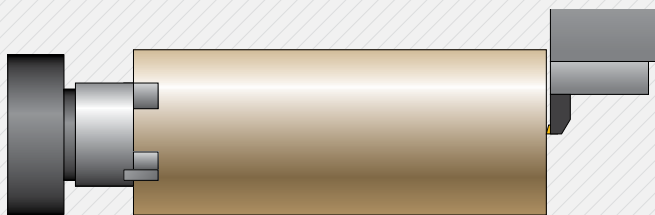
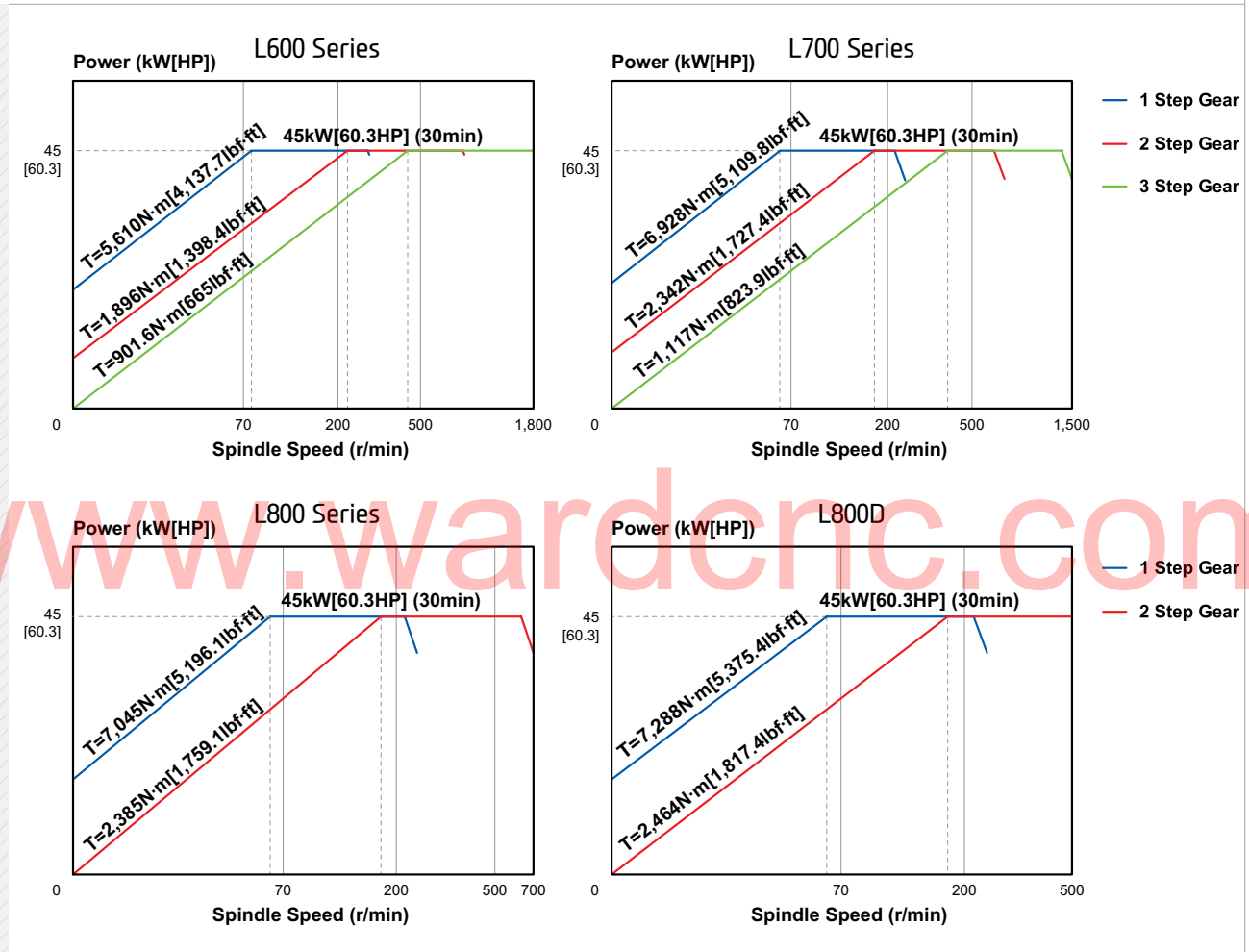

## Large Machining Area

L600/700/800 Series features the largest machining area in its class, which increases the machine's ability to machine large parts.

Max. Turning Dia. : **Ø920 (Ø36.2")** [Steady rest contact dia. : Max. Ø510 (Ø20.1") for SMW K.6.1]

Max. Turning Length : L600A/MA | 700A/MA | 800A/MA | 800D/MD : **1,650 mm (65")**

L600LA/LMA | 700LA/LMA | 800LA/LMA | 800LD/LMD : **3,250 mm (128")**

**n3**  
L600/700/800

## Big Bore Spindle

Long Work Are & Heavy Duty Cutting  
Big Bore Spindle



# Big Bore Spindle

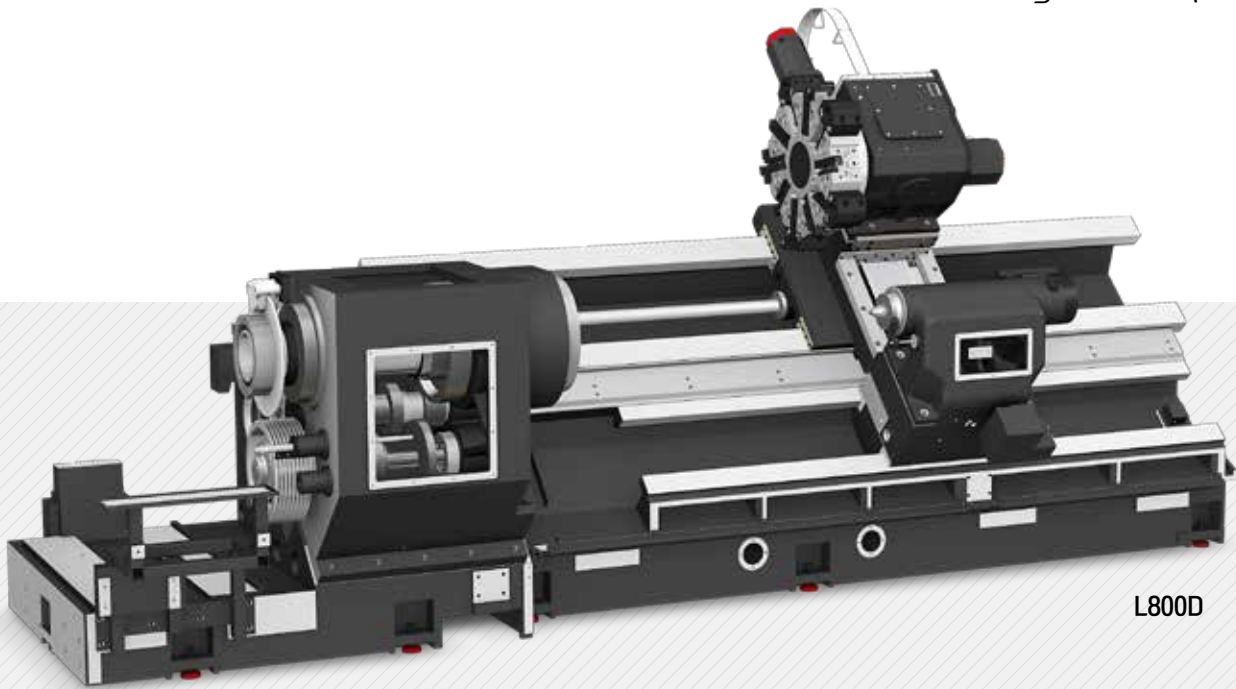

L800D

## L800 Series Big Bore Spindle

Max. Spindle Bore L800LMA :  $\varnothing 320$  ( $\varnothing 12.6''$ ), L800D :  $\varnothing 375$  ( $\varnothing 14.8''$ ) show excellent performance in machining large cylindrical parts for oil and gas industry.

### Air Chucking System **OPTION**

A dual chuck design – one on each end of the spindle – offers superior support of the workpiece such as long shafts or pipe.



(Example)

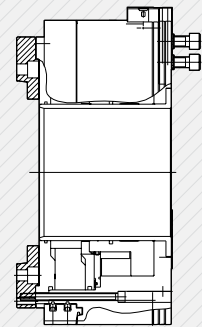
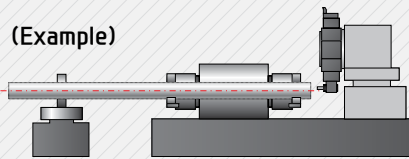

Oil & Gas Pipe Line



# n4

L600/700/800

## Servo Turret

High speed, High Accuracy, Highly Reliable  
Servo Turret



## Mill Turret (BMT85P)

The large 12-station BMT turret enables the L600/700/800 Series to perform high accuracy milling operations in a single set-up.

The BMT turret is driven by a high torque servo motor with a 0.4 second indexing time in either direction



- No. of Tools : 12 EA
- Tool Size (OD/ID) : □ 32/Ø80 ( □ 1.3"/Ø3.1")
- Indexing Time : 0.4 sec/step

### Exchange of BMT Tools

BMT turret increases tool performance and rigidity by securing each tool with 4 screws. Overall cutting power and capability has been improved for various machining operations, including; milling, drilling and tapping



- Output (Max./Cont.) : 11/7.5 kW (14.8/10 HP)
- Speed : 3,000 rpm
- Collet size : Ø34 (Ø1.3") (ER50)
- Live Tool Type : BMT85P

#### Straight Milling Head



#### Angular Milling Head



## Mill Tool Holder

Machining capabilities have been increased with the addition of a straight milling head, which can remove material from the side of the workpiece, and an angular milling head, which can perform I.D. operations.

A wide variety of additional tool holders can further enhance the machines with capabilities that include drilling and tapping, among others.

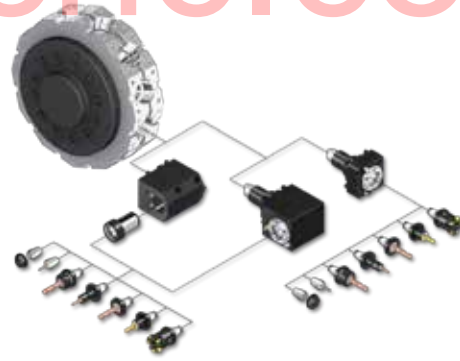

### Turn/Mill Spindle

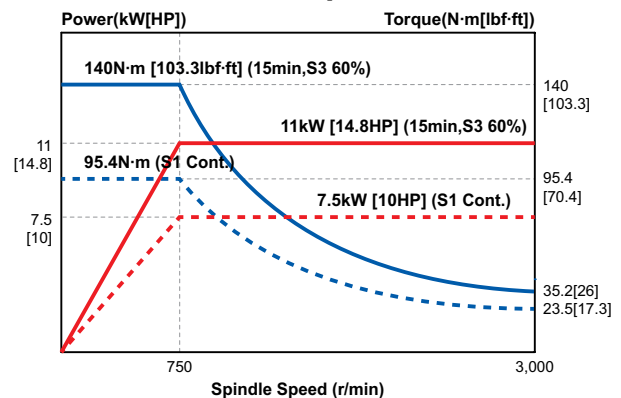

**05**  
L600/700/800

## Machining Capability

Excellent Performance, High Accuracy Cutting  
CNC Turning Center

[www.wardcnc.com](http://www.wardcnc.com)



## L700LMA

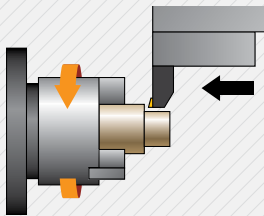

### Heavy-duty cutting (O.D)

(Material:JIS:S45C(Carbon steel))

Spindle rpm	96 r/min
Cutting speed	150 m/min
Cutting depth	12 mm
Forwarding	0.65 mm/rev
Chip discharge	1,170 cc/min

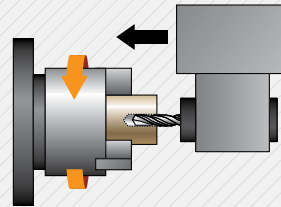

### U-Drilling

(Material:JIS:S45C(Carbon steel))

Tool diameter	Ø180
Cutting speed	130 m/min
Cutting depth	50 mm
Forwarding	0.14 mm/rev
Chip discharge	814 cc/min

❖ The above result might be different by types of processing circumstance

[www.wardenc.com](http://www.wardenc.com)

Sample Workpieces



## Machining Variation

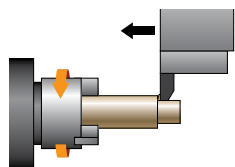

O.D Cutting

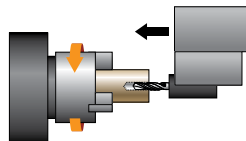

Drilling

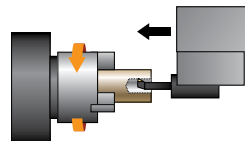

I.D Cutting

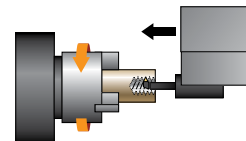

I.D Threading

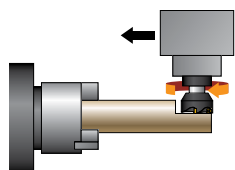

Face Cutting

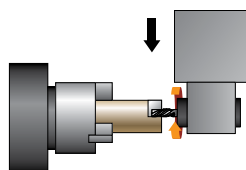

End Milling

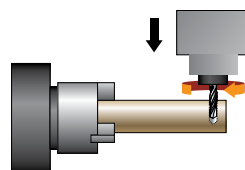

O.D Hole Drilling

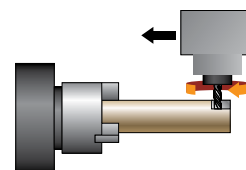

Ball-End Milling

**05**  
L600/700/800

# Smart System



Software for Smart Operating and Machining

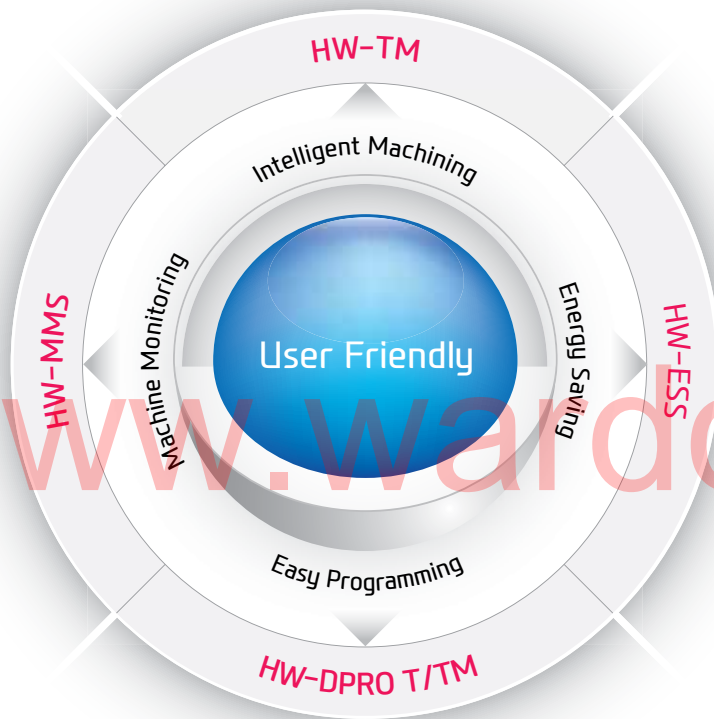

HYUNDAI WIA Smart System  
for CNC Turning Center

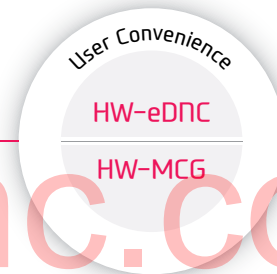

www.wardcnc.com

## Smart Factory HW-MMS (HYUNDAI WIA-Machine Monitoring System)

A brand new manufacturing machine by HYUNDAI WIA, HW-MMS is a unique software capable of monitoring the operation status of manufacturing machines in factories, a smart solution to improve manufacturing conditions of customers.

- 01 Real-time monitoring of machine operation status (Cloud)
- 02 History and statistics of machine operation (Cloud)
- 03 History and statistics of alarm occurrence (Cloud)
- 04 History and statistics of work count (Cloud)
- 05 Remote diagnosis (Remote)



Faster processing and enhanced accuracy in are possible through the **HYUNDAI WIA Smart System**. The user friendly software and equipment monitoring of the Smart System maximizes productivity.



### HW-eDNC

HYUNDAI WIA ethernet  
Direct Numerical Control

This software allows transmission of NC data between PC and a machine's CNC. The processing programs can be managed on the PC through the ethernet or serial communication.



### HW-MCG

HYUNDAI WIA  
Machine Guidance

Software that offers operation, maintenance, management monitoring and various user friendly features.



### HW-TM

HYUNDAI WIA  
Tool Monitoring

A tool monitoring software which analyzes the load of the spindle motor to determine and monitor possible damage of tools.



### HW-ESS (Standard)

HYUNDAI WIA  
Energy Saving System

An environmental friendly software that reduces the unnecessarily wasted standby power waiting for an operation.

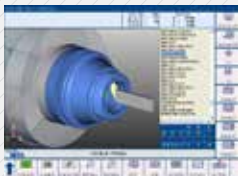

### HW-DPRO T/TM HYUNDAI WIA Dialogue PROGRAM Turn/TurnMill

Using a dialogue method, this software makes it easy to work out a program for a lathe processing operation with complicated configurations. (Can be installed on a PC.)

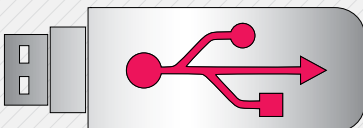

### USB Port

Convenience is increased when inputting and outputting program. The USB port is available in addition to the former input output methods such as CF memmort card and LAN.

# n6

L600/700/800

## User Convenience

Various Devices for User Convenience

### Chuck Type Tail Stock

When machining material like pipe stable product-machining is possible with the use of chuck type tail stock.

- Chuck Size : 12"
- Spindle Speed : 3,000 rpm
- Quill Dia. :  $\varnothing 95$  ( $\varnothing 3.7$ ")

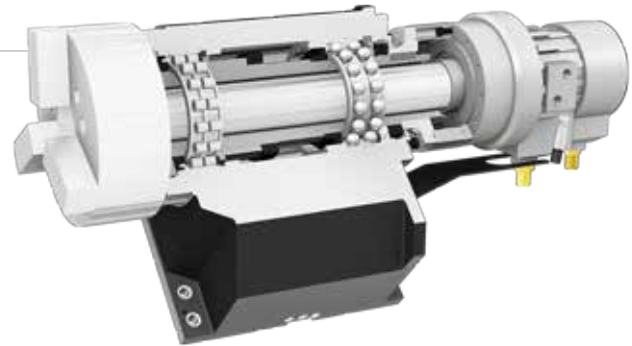

### Steady Rest



For long parts, such as shafts, the optional steady rest increases rigidity and minimizes vibration. When using the programmable hydraulic work rest provided as an option, the position of the work rest can be adjusted according to the shape of the product using the alignment pin connected to the turret. This enhances the efficiency of the machining operation.

※ Steady rest contact dia. : Max.  $\varnothing 510$  ( $\varnothing 20.1$ ") for SMW K.6.1

### Auto Q-Setter

L600/700 Series



Cutting tools are calibrated quickly and accurately with the addition of a Q-Setter.

Each tool tip is touched off automatically by program using a sensor that inputs the position automatically. (L800 Series : Manual Q-Setter)

### Operation Panel

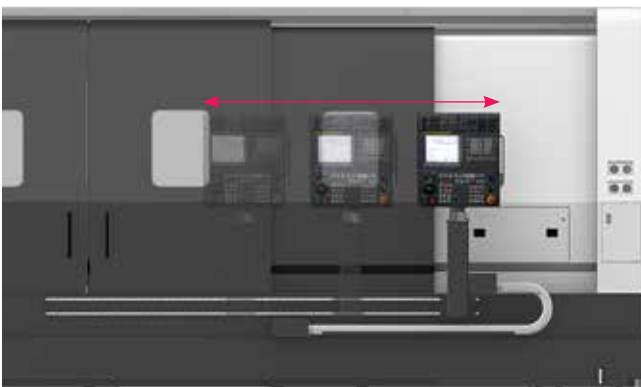

The ergonomic design enhances user convenience.

LM guide is installed at the bottom of the machine to enable smooth movement of the operation panel.



# SPECIFICATIONS

## Standard & Optional

● : Standard ○ : Option ☆ : Prior Consultation - : Non Applicable

Spindle		L600A(LA)	L600MA(LMA)
Main Spindle Hollow Chuck 3 Jaw	18"	○	○
	21"	○	○
	24"	-	-
	18"	-	-
Main Spindle Solid Chuck 3 Jaw	21"	-	-
	24"	-	-
Standard Soft Jaw (1set)		○	○
Chuck Clamp Foot Switch		●	●
2 Steps Hyd. Pressure Device		○	○
Spindle Inside Stopper		☆	☆
5° Index		☆	☆
Cs-Axis (0.001°)		-	●
Chuck Open/Close Confirmation Device		○	○
2 Steps Chuck Foot Switch		○	○
<b>Turret</b>			
Tool Holder		●	●
Mill Turret	BMT	-	●
Straight Milling Head (Radial)	Adaptor Type	-	●
Angular Milling Head (Axial)	Adaptor Type	-	●
Boring Sleeve		●	●
Drill Socket		○	○
U-Drill Cap		●	●
Long Boring Bar I.D Holder		LA ☆	LMA ☆
Angle Head		-	☆
<b>Tail Stock &amp; Steady Rest</b>			
Built-In Tail Stock		●	●
Programmable Tail Stock		●	●
Manual Type Steady Rest		☆	☆
Manual Type Hyd. Steady Rest	1Set	-	-
	2Sets	-	-
Programmable Hyd. Steady Rest	1Set	○	○
	2Sets	LA ○	LMA ○
Fixed center		●	●
2 Steps Tail Stock Pressure System		☆	☆
Quill Forward/Reverse Confirmation Device		○(CE:●)	○(CE:●)
Tail Stock Foot Switch		●	●
<b>Coolant &amp; Air Blow</b>			
Standard Coolant (Nozzle)		●	●
Bed Flushing Coolant		●	●
Chuck Coolant (Upper Chuck)		○	○
Gun Coolant		○	○
Spindle Thru Coolant (Only for Special Chuck)		☆	☆
Thru Coolant for Live Tool		-	-
Chuck Air Blow (Upper Chuck)		○	○
Tail Stock Air Blow (Upper Tail Stock)		☆	☆
Turret Air Blow		☆	☆
Air Gun		○	○
Spindle Thru Air Blow (Only for Special Chuck)		☆	☆
High Pressure Coolant	6Bar (87psi)	●	●
	20Bar (290psi)	○	○
	70Bar (1,015psi)	○	○
Power Coolant System (For Automation)		☆	☆
Coolant Chiller		☆	☆
<b>Chip Disposal</b>			
Coolant Tank	570 ℓ (150.6 gal)	●	●
	770 ℓ (203.4 gal)	LA ●	LMA ●
Chip Conveyor (Hinge/Scraper)	Front (Right)	○	○
	Front (Rear)	-	-
Special Chip Conveyor (Drum Filter)		☆	☆
Chip Wagon	Standard (180 ℓ [47.5 gal])	○	○
	Swing (200 ℓ [52.8 gal])	○	○
	Large Swing (290 ℓ [76.6 gal])	○	○
	Large Size (330 ℓ [87.2 gal])	○	○
	Customized	☆	☆

Safety Device		L600A(LA)	L600MA(LMA)
Total Splash Guard		●	●
Chuck hydraulic pressure maintenance interlock		○(CE:●)	○(CE:●)
<b>Electric Device</b>			
Call Light	1Color : ■	●	●
Call Light	2Color : ■ ■	○	○
Call Light	3Color : ■ ■ ■	○	○
Call Light & Buzzer	3Color : ■ ■ ■ B	○	○
Electric Cabinet Light		○	○
Remote MPG		○	○
Work Counter	Digital	○	○
Total Counter	Digital	○	○
Tool Counter	Digital	○	○
Multi Tool Counter	Digital	○	○
Electric Circuit Breaker		○	○
AVR (Auto Voltage Regulator)		☆	☆
Transformer	70KVA	○	○
Auto Power Off		○	○
<b>Measurement</b>			
Q-Setter		-	-
Automatic Q-Setter		●	●
Work Close Confirmation Device (Only for Special Chuck)	TACO	☆	☆
	SMC	☆	☆
Work Setter		○	○
Linear Scale	X Axis	○	○
	Z Axis	○	○
Coolant Level Sensor (Only for Chip Conveyor)		☆	☆
<b>Environment</b>			
Air Conditioner		○	○
Oil Mist Collector		☆	☆
Oil Skimmer		○	○
MQL (Minimal Quantity Lubrication)		☆	☆
<b>Fixture &amp; Automation</b>			
Auto Door	Standard	○	○
	High Speed	☆	☆
Auto Shutter (Only for Automatic System)		-	-
Sub Operation Pannel		☆	☆
Bar Feeder Interface		○	○
Bar Feeder (FEDEK)		☆	☆
Extra M-Code 4ea		○	○
Automation Interface		☆	☆
I/O Extension (IN & OUT)	16 Contact	○	○
	32 Contact	○	○
Parts Catcher		-	-
Turret Work Pusher (For Automation)		☆	☆
<b>Hyd. Device</b>			
Standard Hyd. Cylinder		●	●
Standard Hyd. Unit		●	●
		58bar(841.2psi) / 63 ℓ (16.6 gal)	
<b>S/W</b>			
Machine Guidance (HW-MCG)		☆	☆
Energy Saving System (HW-ESS)		●	●
Tool Monitoring (HW-TM)		○	○
DNC software (HW-eDNC)		○	○
Machine Monitoring System (HW-MMS)		☆	☆
Conversational program (HW-DPRO)		○	○
<b>ETC</b>			
Tool Box		●	●
Customized Color	Need Munsel No.	☆	☆
CAD & CAM		☆	☆

Prior consultation is required when applying spindle contouring control for gear driven spindle. Specifications are subject to change without notice for improvement.

# SPECIFICATIONS

## Standard & Optional

Spindle		L700A(LA)	L700MA(LMA)
Main Spindle Hollow Chuck 3 Jaw	18"	-	-
	21"	-	-
	24"	○	○
Main Spindle Solid Chuck 3 Jaw	18"	-	-
	21"	-	-
	24"	-	-
Standard Soft Jaw (1set)		○	○
Chuck Clamp Foot Switch		●	●
2 Steps Hyd. Pressure Device		○	○
Spindle Inside Stopper		☆	☆
5" Index		☆	☆
Cs-Axis (0.001")		-	●
Chuck Open/Close Confirmation Device		○	○
2 Steps Chuck Foot Switch		○	○
<b>Turret</b>			
Tool Holder		●	●
Mill Turret	BMT	-	●
Straight Milling Head (Radial)	Adaptor Type	-	●
Angular Milling Head (Axial)	Adaptor Type	-	●
Boring Sleeve		●	●
Drill Socket		○	○
U-Drill Cap		●	●
Long Boring Bar I.D Holder		LA ☆	LMA ☆
Angle Head		-	☆
<b>Tail Stock &amp; Steady Rest</b>			
Built-In Tail Stock		●	●
Programmable Tail Stock		●	●
Manual Type Steady Rest		☆	☆
Manual Type Hyd. Steady Rest	1Set	-	-
	2Sets	-	-
Programmable Hyd. Steady Rest	1Set	○	○
	2Sets	LA ○	LMA ○
Fixed center		●	●
2 Steps Tail Stock Pressure System		☆	☆
Quill Forward/Reverse Confirmation Device		○(CE:●)	○(CE:●)
Tail Stock Foot Switch		●	●
<b>Coolant &amp; Air Blow</b>			
Standard Coolant (Nozzle)		●	●
Bed Flushing Coolant		●	●
Chuck Coolant (Upper Chuck)		○	○
Gun Coolant		○	○
Spindle Thru Coolant (Only for Special Chuck)		☆	☆
Thru Coolant for Live Tool		-	-
Chuck Air Blow (Upper Chuck)		○	○
Tail Stock Air Blow (Upper Tail Stock)		☆	☆
Turret Air Blow		☆	☆
Air Gun		○	○
Spindle Thru Air Blow (Only for Special Chuck)		☆	☆
High Pressure Coolant	6Bar (87psi)	●	●
	20Bar (290psi)	○	○
	70Bar (1,015psi)	○	○
Power Coolant System (For Automation)		☆	☆
Coolant Chiller		☆	☆
<b>Chip Disposal</b>			
Coolant Tank	570 ℓ (150.6 gal)	●	●
	770 ℓ (203.4 gal)	LA ●	LMA ●
Chip Conveyor (Hinge/Scraper)	Front (Right)	○	○
	Front (Rear)	-	-
Special Chip Conveyor (Drum Filter)		☆	☆
Chip Wagon	Standard (180 ℓ [47.5 gal])	○	○
	Swing (200 ℓ [52.8 gal])	○	○
	Large Swing (290 ℓ [76.6 gal])	○	○
	Large Size (330 ℓ [87.2 gal])	○	○
	Customized	☆	☆

● : Standard ○ : Option ☆ : Prior Consultation - : Non Applicable

Safety Device		L700A(LA)	L700MA(LMA)
Total Splash Guard		●	●
Chuck hydraulic pressure maintenance interlock		○(CE:●)	○(CE:●)
<b>Electric Device</b>			
Call Light	1Color : ●	●	●
	2Color : ● ●	○	○
Call Light	3Color : ● ● ●	○	○
Call Light & Buzzer	3Color : ● ● ● B	○	○
Electric Cabinet Light		○	○
Remote MPG		○	○
Work Counter	Digital	○	○
Total Counter	Digital	○	○
Tool Counter	Digital	○	○
Multi Tool Counter	Digital	○	○
Electric Circuit Breaker		○	○
AVR (Auto Voltage Regulator)		☆	☆
Transformer	70kVA	○	○
Auto Power Off		○	○
<b>Measurement</b>			
Q-Setter		-	-
Automatic Q-Setter		●	●
Work Close Confirmation Device (Only for Special Chuck)	TACO	☆	☆
	SMC	☆	☆
Work Setter		○	○
Linear Scale	X Axis	○	○
	Z Axis	○	○
Coolant Level Sensor (Only for Chip Conveyor)		☆	☆
<b>Environment</b>			
Air Conditioner		○	○
Oil Mist Collector		☆	☆
Oil Skimmer		○	○
MLQ (Minimal Quantity Lubrication)		☆	☆
<b>Fixture &amp; Automation</b>			
Auto Door	Standard	○	○
	High Speed	☆	☆
Auto Shutter (Only for Automatic System)		-	-
Sub Operation Pannel		☆	☆
Bar Feeder Interface		○	○
Bar Feeder (FEDEK)		☆	☆
Extra M-Code 4ea		○	○
Automation Interface		☆	☆
I/O Extension (IN & OUT)	16 Contact	○	○
	32 Contact	○	○
Parts Catcher	Main SP.	-	-
Turret Work Pusher (For Automation)		☆	☆
<b>Hyd. Device</b>			
Standard Hyd. Cylinder	Hollow	●	●
Standard Hyd. Unit	58bar(841.2psi) / 63 ℓ (16.6 gal)	●	●
<b>S/W</b>			
Machine Guidance (HW-MCG)		☆	☆
Energy Saving System (HW-ESS)		●	●
Tool Monitoring (HW-TM)		○	○
DNC software (HW-eDNC)		○	○
Machine Monitoring System (HW-MMS)		☆	☆
Conversational program (HW-DPRO)		○	○
<b>ETC</b>			
Tool Box		●	●
Customized Color	Need Munsel No.	☆	☆
CAD & CAM		☆	☆

# SPECIFICATIONS

## Standard & Optional

● : Standard ○ : Option ☆ : Prior Consultation - : Non Applicable

Spindle		L800A(LA)	L800MA(LMA)
Main Spindle Hollow Chuck 3 Jaw	18"	-	-
	21"	-	-
	24"	-	-
	32"	○	○
Main Spindle Solid Chuck 3 Jaw	18"	-	-
	21"	-	-
	24"	-	-
	32"	-	-
Big Bore Air Chuck	○	○	
Standard Soft Jaw (1set)	○	○	
Chuck Clamp Foot Switch	●	●	
2 Steps Hyd. Pressure Device	○	○	
Spindle Inside Stopper	☆	☆	
5° Index	☆	☆	
C5-Axis (0.001°)	-	●	
Chuck Open/Close Confirmation Device	○	○	
2 Steps Chuck Foot Switch	○	○	
<b>Turret</b>			
Tool Holder		●	●
Mill Turret	BMT	-	●
Straight Milling Head (Radial)	Adaptor Type	-	●
Angular Milling Head (Axial)	Adaptor Type	-	●
Boring Sleeve		●	●
Drill Socket		○	○
U-Drill Cap		●	●
Long Boring Bar I.D Holder		LA ☆	LMA ☆
Angle Head		-	☆
<b>Tail Stock &amp; Steady Rest</b>			
Built-In Tail Stock		●	●
Programmable Tail Stock		●	●
Manual Type Steady Rest		☆	☆
Manual Type Hyd. Steady Rest	1Set	-	-
	2Sets	-	-
Programmable Hyd. Steady Rest	1Set	○	○
	2Sets	LA ○	LMA ○
Fixed center		●	●
2 Steps Tail Stock Pressure System		☆	☆
Quill Forward/Reverse Confirmation Device		○(CE:●)	○(CE:●)
Tail Stock Foot Switch		●	●
<b>Coolant &amp; Air Blow</b>			
Standard Coolant (Nozzle)		●	●
Bed Flushing Coolant		●	●
Chuck Coolant (Upper Chuck)		○	○
Gun Coolant		○	○
Spindle Thru Coolant (Only for Special Chuck)		☆	☆
Thru Coolant for Live Tool		-	-
Chuck Air Blow (Upper Chuck)		○	○
Tail Stock Air Blow (Upper Tail Stock)		☆	☆
Turret Air Blow		☆	☆
Air Gun		○	○
Spindle Thru Air Blow (Only for Special Chuck)		☆	☆
High Pressure Coolant	6Bar (87psi)	●	●
	20Bar (290psi)	○	○
	70Bar (1,015psi)	○	○
Power Coolant System (For Automation)		☆	☆
Coolant Chiller		☆	☆
<b>Chip Disposal</b>			
Coolant Tank	570 ℓ (150.6 gal)	●	●
	770 ℓ (203.4 gal)	LA ●	LMA ●
	Front (Right)	○	○
Chip Conveyor (Hinge/Scraper)	Front (Rear)	-	-
	Special Chip Conveyor (Drum Filter)	☆	☆
Chip Wagon	Standard (180 ℓ [47.5 gal])	○	○
	Swing (200 ℓ [52.8 gal])	○	○
	Large Swing (290 ℓ [76.6 gal])	○	○

Chip Disposal		L800A(LA)	L800MA(LMA)
Chip Wagon	Large Size (330 ℓ [87.2 gal])	○	○
	Customized	☆	☆
	<b>Safety Device</b>		
Total Splash Guard		●	●
Chuck hydraulic pressure maintenance interlock		○(CE:●)	○(CE:●)
<b>Electric Device</b>			
Call Light	1Color : ●	●	●
Call Light	2Color : ●●	○	○
Call Light	3Color : ●●●	○	○
Call Light & Buzzer	3Color : ●●● B	○	○
Electric Cabinet Light		○	○
Remote MPG		○	○
Work Counter	Digital	○	○
Total Counter	Digital	○	○
Tool Counter	Digital	○	○
Multi Tool Counter	Digital	○	○
Electric Circuit Breaker		○	○
AVR (Auto Voltage Regulator)		☆	☆
Transformer	70kVA	○	○
Auto Power Off		○	○
<b>Measurement</b>			
Q-Setter		○	○
Automatic Q-Setter		-	-
Work Close Confirmation Device (Only for Special Chuck)	TACO	☆	☆
	SMC	☆	☆
Work Setter		○	○
Linear Scale	X Axis	○	○
	Z Axis	○	○
Coolant Level Sensor (Only for Chip Conveyor)		☆	☆
<b>Environment</b>			
Air Conditioner		○	○
Oil Mist Collector		☆	☆
Oil Skimmer		○	○
MQL (Minimal Quantity Lubrication)		☆	☆
<b>Fixture &amp; Automation</b>			
Auto Door	Standard	○	○
	High Speed	☆	☆
Auto Shutter (Only for Automatic System)		-	-
Sub Operation Pannel		☆	☆
Bar Feeder Interface		○	○
Bar Feeder (FEDEK)		☆	☆
Extra M-Code 4ea		○	○
Automation Interface		☆	☆
I/O Extension (IN & OUT)	16 Contact	○	○
	32 Contact	○	○
Parts Catcher	Main SP.	-	-
Turret Work Pusher (For Automation)		☆	☆
<b>Hyd. Device</b>			
Standard Hyd. Cylinder	Hollow	○	○
Standard Hyd. Unit	58bar(841.2psi) / 63 ℓ (16.6 gal)	●	●
<b>S/W</b>			
Machine Guidance (HW-MCG)		☆	☆
Energy Saving System (HW-ESS)		●	●
Tool Monitoring (HW-TM)		○	○
DNC software (HW-eDNC)		○	○
Machine Monitoring System (HW-MMS)		☆	☆
Conversational program (HW-DPRO)		○	○
<b>ETC</b>			
Tool Box		●	●
Customized Color	Need Munsel No.	☆	☆
CAD & CAM		☆	☆

# SPECIFICATIONS

## Standard & Optional

Spindle		L800D(LD)	L800MD(LMD)
Main Spindle Hollow Chuck 3 Jaw	18"	-	-
	21"	-	-
	24"	-	-
	32"	-	-
Main Spindle Solid Chuck 3 Jaw	18"	-	-
	21"	-	-
	24"	-	-
	32"	-	-
Big Bore Air Chuck	34"	○	○
Big Bore Independent Chuck	32"	○	○
Standard Soft Jaw (1set)		○	○
Chuck Clamp Foot Switch		●	●
2 Steps Hyd. Pressure Device		○	○
Spindle Inside Stopper		☆	☆
Main Spindle 5° Index		☆	☆
C-Axis (0.001")		-	●
Chuck Open/Close Confirmation Device		○	○
2 Steps Chuck Foot Switch		○	○
<b>Turret</b>			
Tool Holder		●	●
Mill Turret	BMT	-	●
Straight Milling Head (Radial)	Collet Type	-	●
Angular Milling Head (Axial)	Collet Type	-	●
Boring Sleeve		●	●
Drill Socket		○	○
U-Drill Cap		●	●
Long Boring Bar I.D Holder		LD ☆	LMD ☆
Angle Head		-	☆
<b>Tail Stock &amp; Steady Rest</b>			
Built-In Tail Stock		○	○
Programmable Tail Stock		○	○
Manual Type Steady Rest		☆	☆
Programmable	1Set	○	○
Hyd. Steady Rest	2Sets	LD ○	LMD ○
Fixed center	Selecting Tail Stock (●)	Selecting Tail Stock (●)	
2 Steps Tail Stock Pressure System	Selecting Tail Stock (☆)	Selecting Tail Stock (☆)	
Quill Forward/Reverse Confirmation Device	Selecting Tail Stock (●)	Selecting Tail Stock (●)	
Tail Stock Foot Switch	Selecting Tail Stock (●)	Selecting Tail Stock (●)	
<b>Coolant &amp; Air Blow</b>			
Standard Coolant (Nozzle)		●	●
Bed Flushing Coolant		●	●
Chuck Coolant (Upper Chuck)		○	○
Gun Coolant		○	○
Spindle Thru Coolant (Only for Special Chuck)		☆	☆
Thru Coolant for Live Tool		-	-
Chuck Air Blow (Upper Chuck)		○	○
Tail Stock Air Blow (Upper Tail Stock)		☆	☆
Turret Air Blow		☆	☆
Air Gun		○	○
Spindle Thru Air Blow (Only for Special Chuck)		☆	☆
High Pressure Coolant	6Bar (87psi)	●	●
	20Bar (290psi)	○	○
	70Bar (1,015psi)	○	○
Power Coolant System (For Automation)		☆	☆
Coolant Chiller		☆	☆
<b>Chip Disposal</b>			
Coolant Tank	570 ℓ (150.6 gal)	●	●
	770 ℓ (203.4 gal)	LD ●	LMD ●
Chip Conveyor (Hinge/Scraper)	Front (Right)	○	○
	Front (Rear)	-	-
Special Chip Conveyor (Drum Filter)		☆	☆
Chip Wagon	Standard (180 ℓ [47.5 gal])	○	○
	Swing (200 ℓ [52.8 gal])	○	○
	Large Swing (290 ℓ [76.6 gal])	○	○
	Large Size (330 ℓ [87.2 gal])	○	○
	Customized	☆	☆

● : Standard ○ : Option ☆ : Prior Consultation - : Non Applicable

Safety Device		L800D(LD)	L800MD(LMD)
Total Splash Guard		●	●
Chuck hydraulic pressure maintenance interlock		○(CE:●)	○(CE:●)
<b>Electric Device</b>			
Call Light	1Color : ●	●	●
Call Light	2Color : ● ●	○	○
Call Light	3Color : ● ● ●	○	○
Call Light & Buzzer	3Color : ● ● ● B	○	○
Electric Cabinet Light		○	○
Remote MPG		○	○
Work Counter	Digital	○	○
Total Counter	Digital	○	○
Tool Counter	Digital	○	○
Multi Tool Counter	Digital	○	○
Electric Circuit Breaker		○	○
AVR (Auto Voltage Regulator)		☆	☆
Transformer	70KVA	○	○
Auto Power Off		○	○
<b>Measurement</b>			
Q-Setter		○	○
Automatic Q-Setter		-	-
Work Close Confirmation Device (Only for Special Chuck)	TACO	☆	☆
	SMC	☆	☆
Work Setter		○	○
Linear Scale	X Axis	○	○
	Z Axis	○	○
Coolant Level Sensor (Only for Chip Conveyor)		☆	☆
<b>Environment</b>			
Air Conditioner		○	○
Oil Mist Collector		☆	☆
Oil Skimmer		○	○
MLQ (Minimal Quantity Lubrication)		☆	☆
<b>Fixture &amp; Automation</b>			
Auto Door	Standard	○	○
	High Speed	☆	☆
Auto Shutter (Only for Automatic System)		-	-
Sub Operation Pannel		☆	☆
Bar Feeder Interface		-	-
Bar Feeder (FEDEK)		-	-
Extra M-Code 4ea		○	○
Automation Interface		☆	☆
I/O Extension (IN & OUT)	16 Contact	○	○
	32 Contact	○	○
Parts Catcher	Main SP.	-	-
Turret Work Pusher (For Automation)		☆	☆
<b>Hyd. Device</b>			
Standard Hyd. Cylinder	Hollow	-	-
Standard Hyd. Unit	58bar(841.2psi) / 63 ℓ (16.6 gal)	●	●
<b>S/W</b>			
Machine Guidance (HW-MCG)		☆	☆
Energy Saving System (HW-ESS)		●	●
Tool Monitoring (HW-TM)		○	○
DNC software (HW-eDNC)		○	○
Machine Monitoring System (HW-MMS)		☆	☆
Conversational program (HW-DPRO)		○	○
<b>ETC</b>			
Tool Box		●	●
Customized Color	Need Munsel No.	☆	☆
CAD & CAM		☆	☆

Prior consultation is required when applying spindle contouring control for gear driven spindle. Specifications are subject to change without notice for improvement.

# SPECIFICATIONS

## External Dimensions

unit : mm(in)

### L600A/600MA/700A/700MA/800A/800MA/800D/800MD

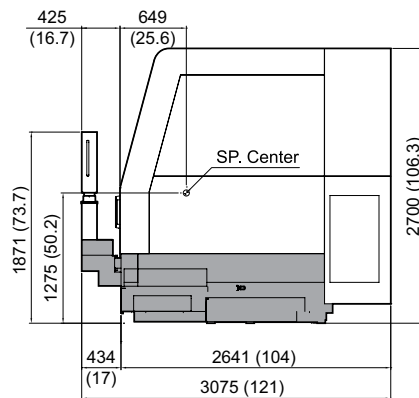
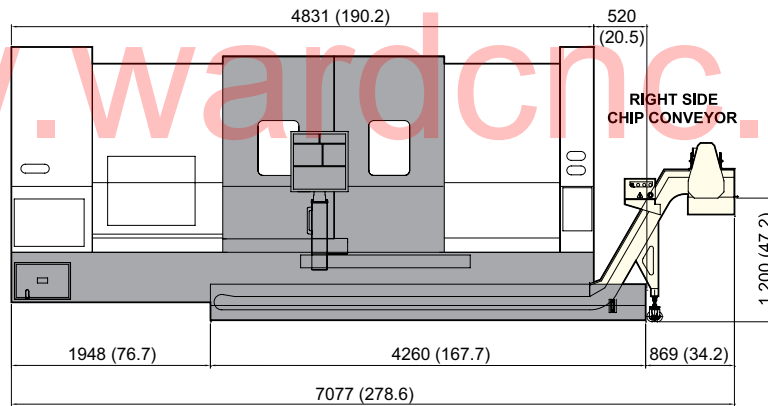
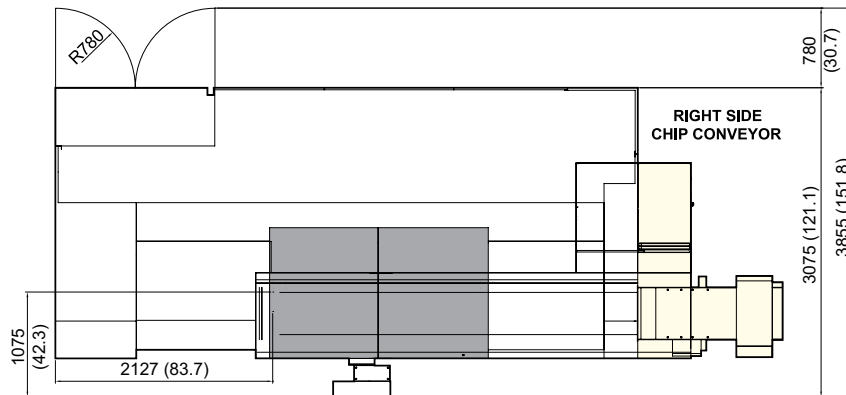

# SPECIFICATIONS

## External Dimensions

unit : mm(in)

L600LA/600LMA/700LA/700LMA/800LA/800LMA/800LD/800LMD

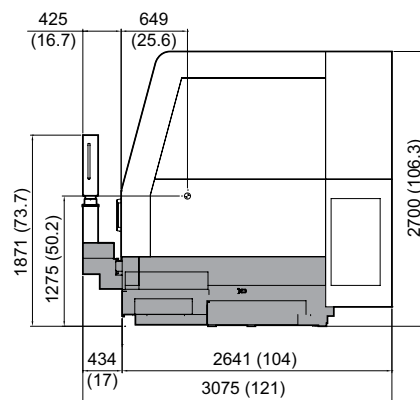
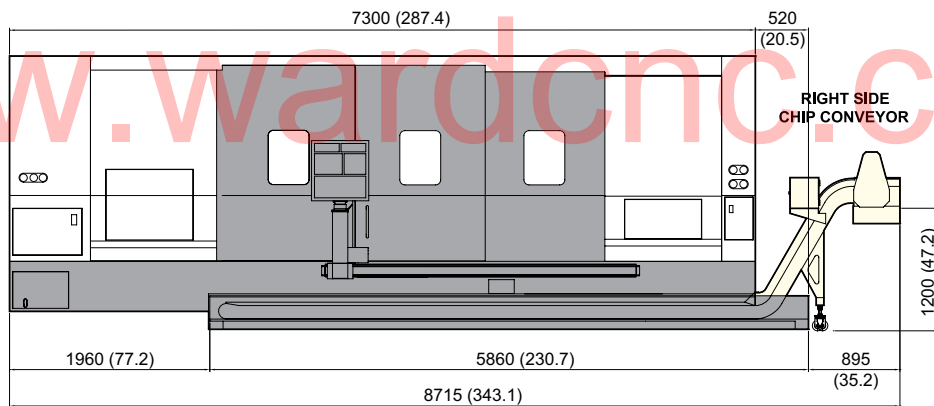
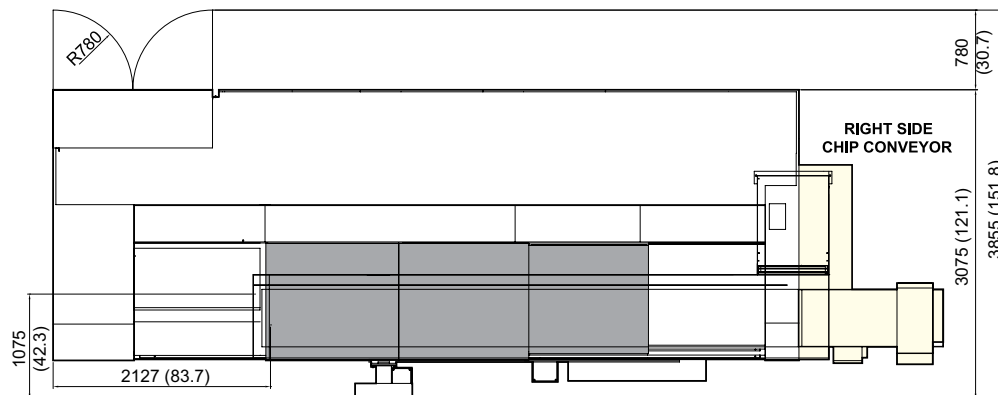



# SPECIFICATIONS

## Tooling System

unit : mm(in)

### L600A/600LA/700A/700LA/800A/800LA/800D/800LD

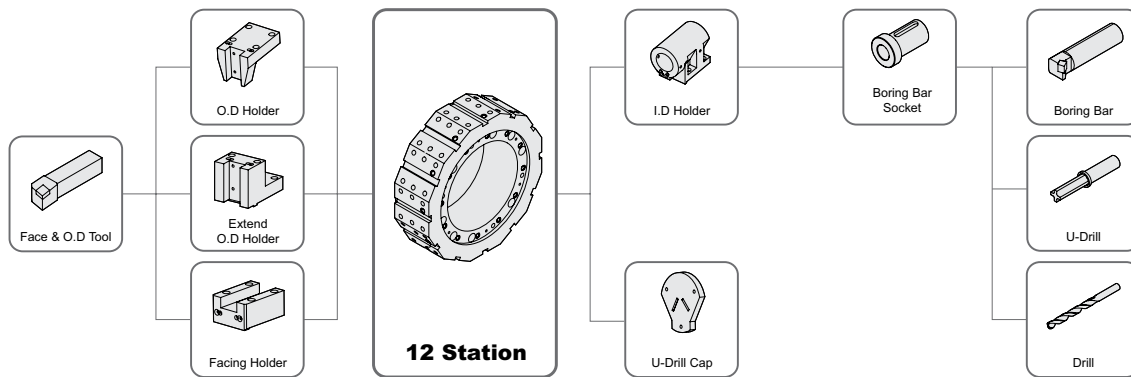

www.wardcnc.com

### L600/700/800 Series Tooling Parts Detail

ITEM			A/D		LA/LD	
			mm Unit	inch Unit	mm Unit	inch Unit
Turning Holder	O.D Holder	Right/Left	4	4	4	4
		Extended	1	1	1	1
	Facing Holder	1	1	1	1	
Boring Holder	I.D Holder	Single	6	6	6	6
		Long (SET)	-	-	Opt	Opt
Driven Holder	Straight Mill Holder	Standard	-	-	-	-
	Angular Mill Holder	Standard	-	-	-	-
Socket	Boring	Ø20 (Ø3/4")	1	1	1	1
		Ø25 (Ø1")	1	1	1	1
		Ø32 (Ø1 1/4")	1	1	1	1
		Ø40 (Ø1 1/2")	1	1	1	1
		Ø50 (Ø2")	1	1	1	1
		Ø60 (Ø2 1/4")	1	1	1	1
	Drill	MT 3	Opt	Opt	Opt	Opt
		MT 4	Opt	Opt	Opt	Opt
		MT 5	Opt	Opt	Opt	Opt
	Adapter Set		-	-	-	-

Specifications are subject to change without notice for improvement.

# SPECIFICATIONS

Tooling System

unit : mm(in)

L600MA/600LMA/700MA/700LMA/800MA/800LMA/800MD/800LMD

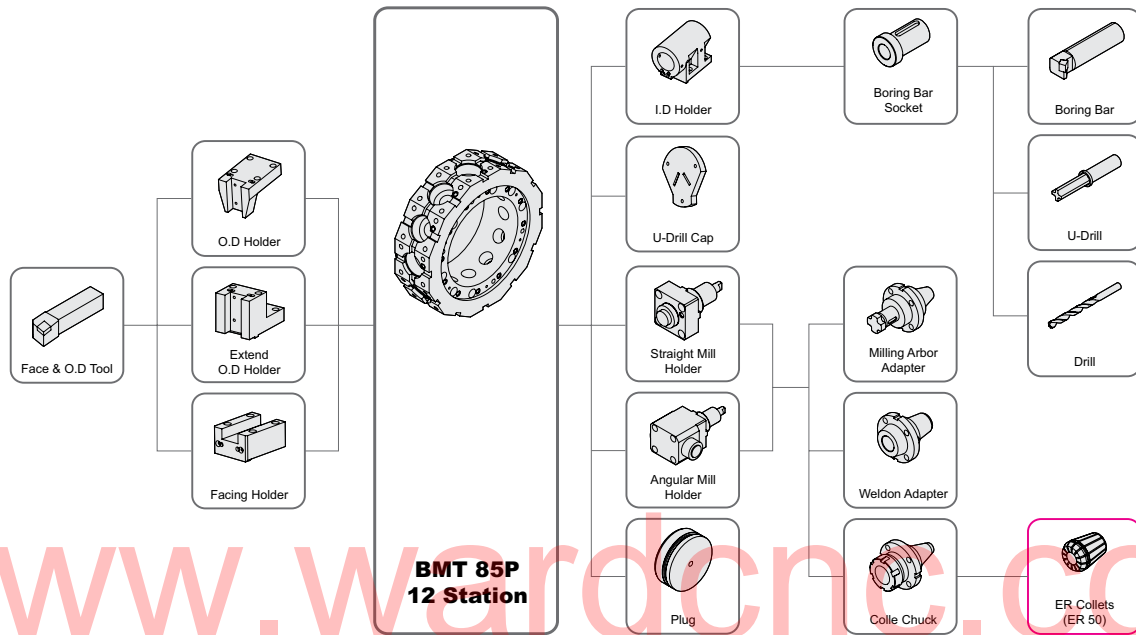

L600/700/800 Series Tooling Parts Detail

ITEM			MA/MD		LMA/LMD	
			mm Unit	inch Unit	mm Unit	inch Unit
Turning Holder	O.D Holder	Right/Left	3	3	3	3
		Extended	1	1	1	1
	Facing Holder	1	1	1	1	
Boring Holder	I.D Holder	Single	5	5	5	5
		Long (SET)	-	-	Opt	Opt
Driven Holder	Straight Mill Holder	Standard	1	1	1	1
	Angular Mill Holder	Standard	1	1	1	1
Socket	Boring	Ø20 (Ø3/4")	1	1	1	1
		Ø25 (Ø1")	1	1	1	1
		Ø32 (Ø1 1/4")	1	1	1	1
		Ø40 (Ø1 1/2")	1	1	1	1
		Ø50 (Ø2")	1	1	1	1
		Ø60 (Ø2 1/4")	1	1	1	1
	Drill	MT 3	Opt	Opt	Opt	Opt
		MT 4	Opt	Opt	Opt	Opt
		MT 5	Opt	Opt	Opt	Opt
	Adapter Set		1 Set	1 Set	1 Set	1 Set

# SPECIFICATIONS

## Interference

unit : mm(in)

### L600A/600LA/700A/700LA/800A/800LA/800D/800LD

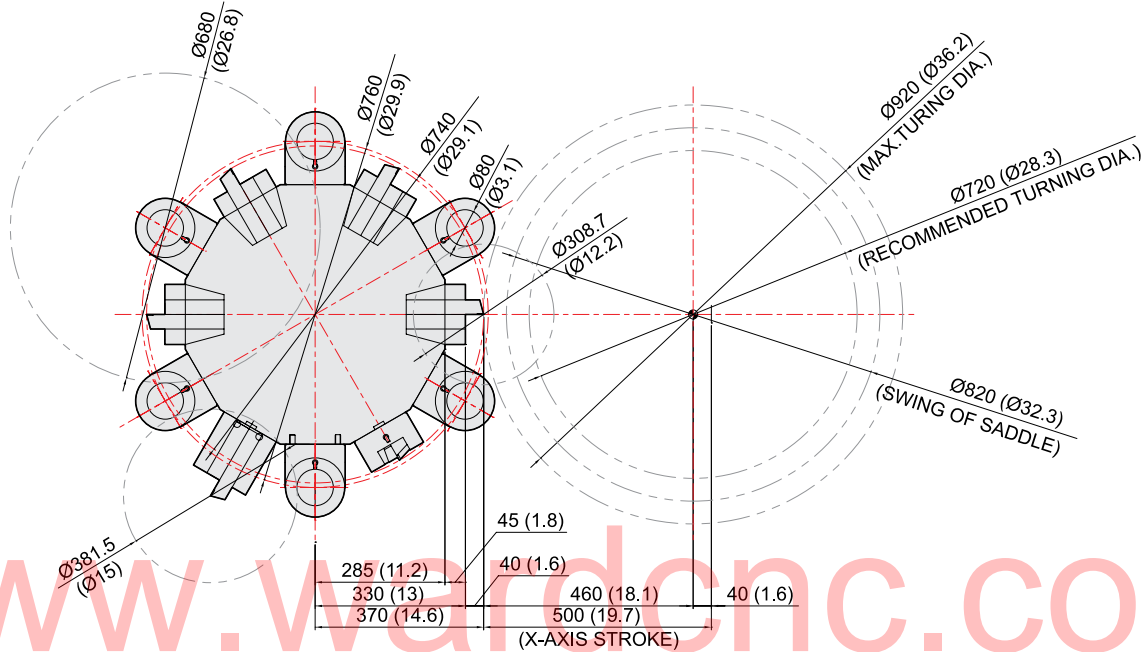

### L600MA/600LMA/700MA/700LMA/800MA/800LMA

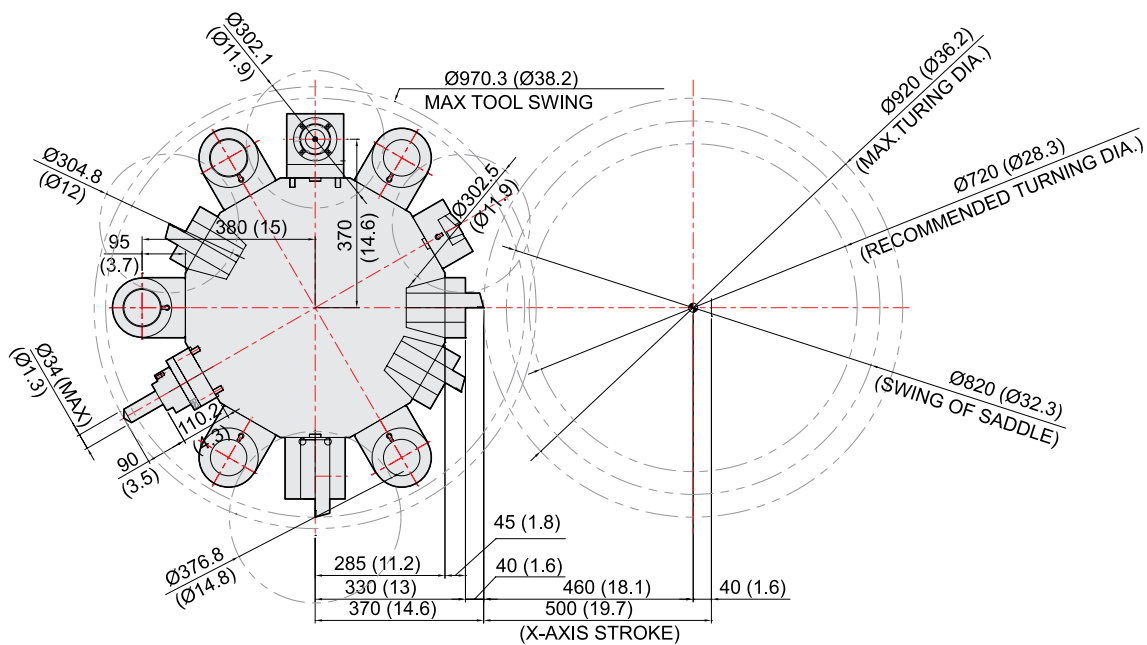

# SPECIFICATIONS

Interference

unit : mm(in)

L600A/600MA/700A/700MA/800A/800MA/800D

## OD TOOL HOLDER

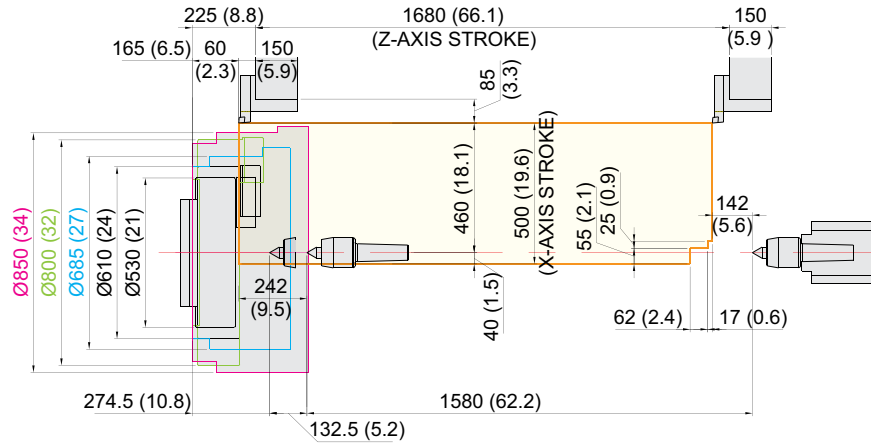

## ID TOOL HOLDER

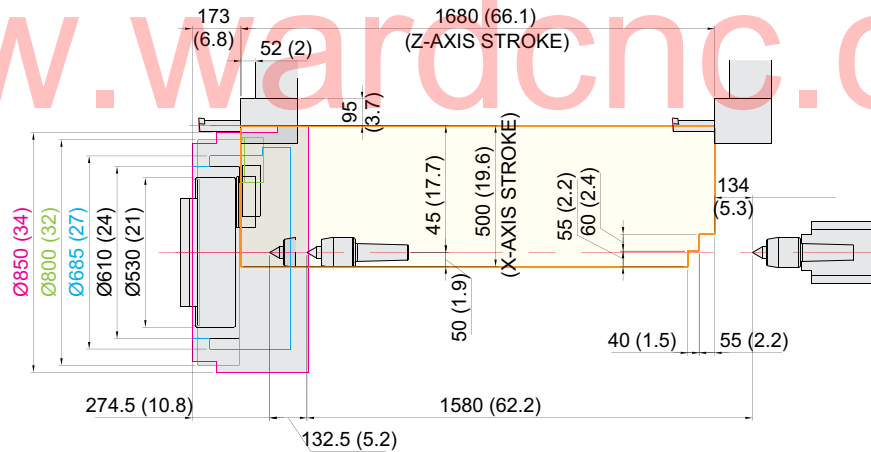

## EXTEND OD TOOL HOLDER

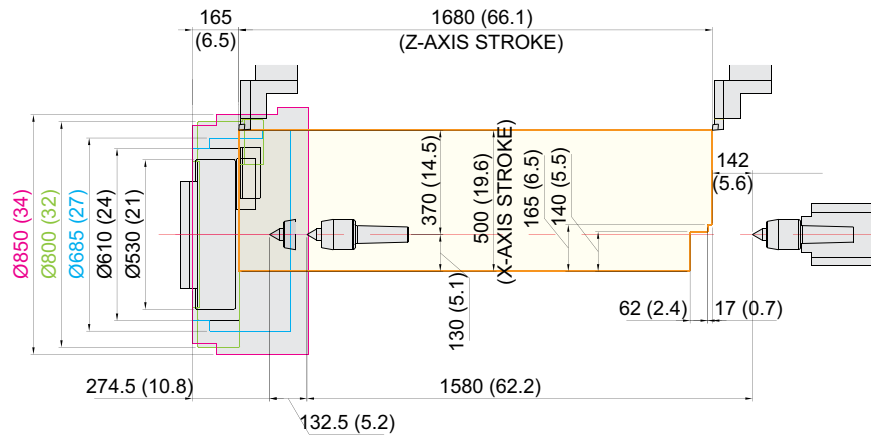

# SPECIFICATIONS

## Tooling Travel Range

unit : mm(in)

L600MA/700MA/800MA/800MD

### STRAIGHT MILLING HEAD

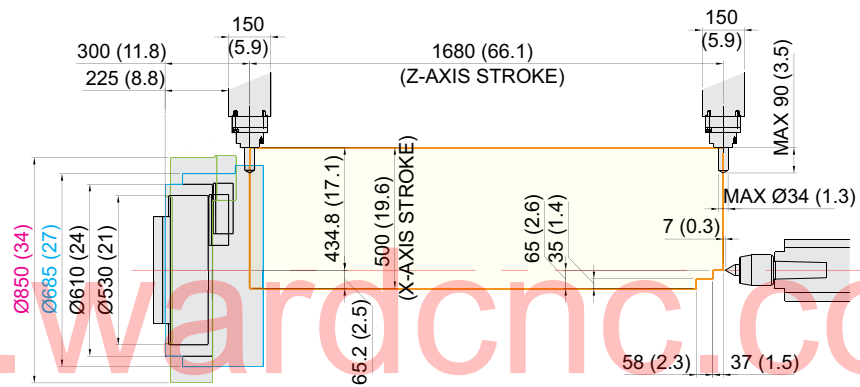

### ANGULAR MILLING HEAD

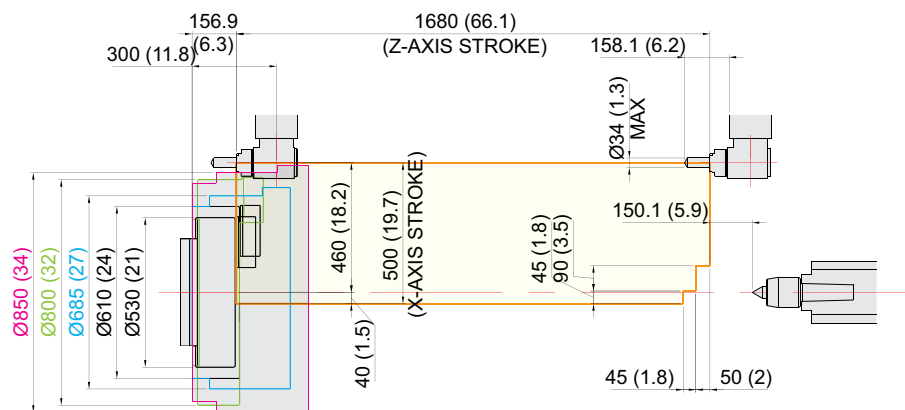

# SPECIFICATIONS

Interference

unit : mm(in)

L600LA/600LMA/700LA/700LMA/800LA/800LMA/800LD/800LMD

## OD TOOL HOLDER

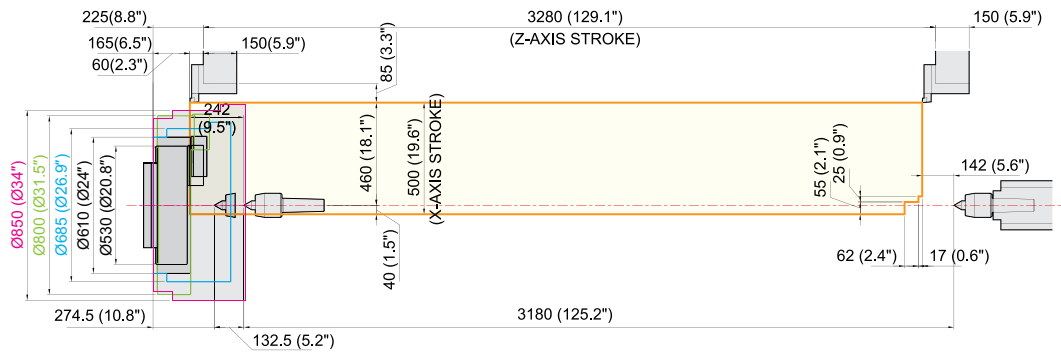

## ID TOOL HOLDER

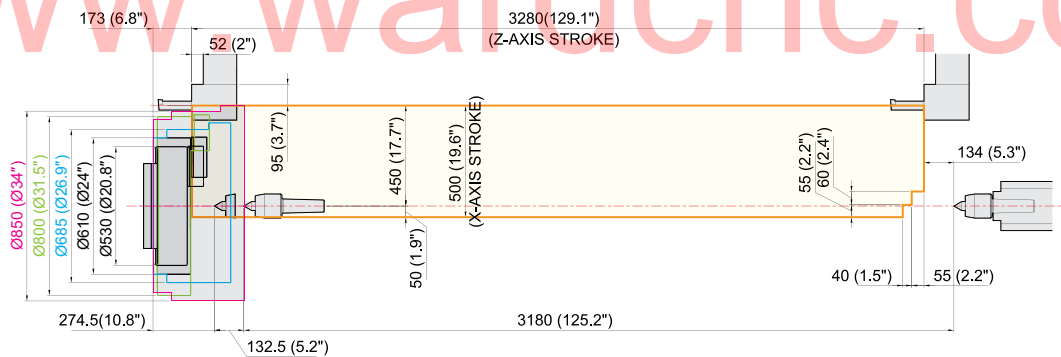

## EXTEND OD TOOL HOLDER

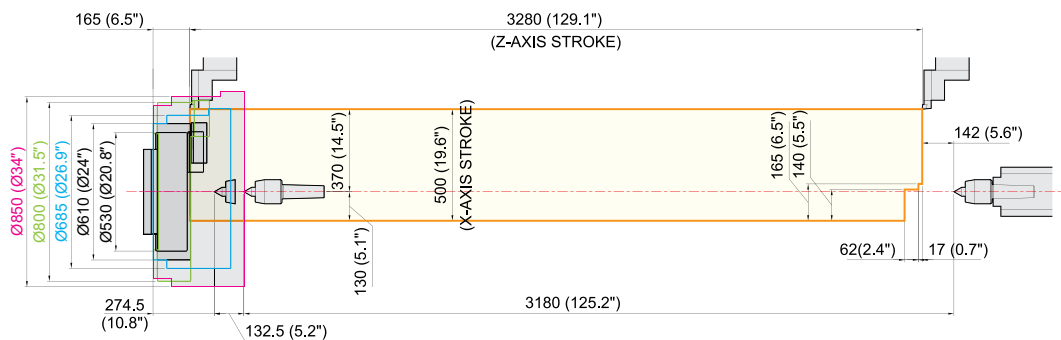

www.wardcnc.com

# SPECIFICATIONS

## Tooling Travel Range

unit : mm(in)

L600LMA/700LMA/800LMA/800LMD

### STRAIGHT MILLING HEAD

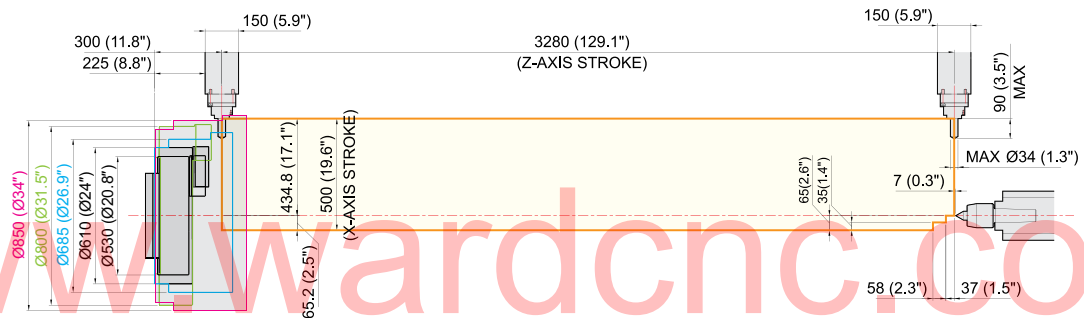

### ANGULAR MILLING HEAD

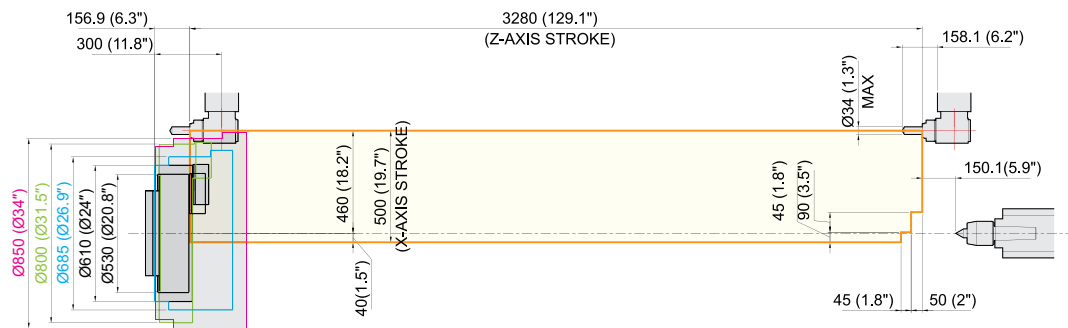

# SPECIFICATIONS

## Specifications

[ ] : Option

ITEM		L600A	L600MA	L600LA	L600LMA	
CAPACITY	Swing Over the Bed	mm(in)	Ø1,050 (41.3")			
	Swing Over the Carriage	mm(in)	Ø820 (32.3")			
	Max. Turning Dia.	mm(in)	Ø920 (36.2")			
	Max. Turning Length	mm(in)	1,650 (65")	3,250 (128")		
	Bar Capacity	mm(in)	{18": Ø117 (Ø4.6")} {21": Ø139 (Ø5.5")}			
SPINDLE	Chuck Size	inch	Opt. [18"/21"]			
	Spindle Bore	mm(in)	Ø152 (6")			
	Spindle Speed (rpm)	r/min	1,800			
	Motor (30min./Cont.)	kW(HP)	45/37 (60.3/49.6)			
	Torque (30min./Cont.)	N·m(lbf·ft)	5,610 / 4,621 (4,137.7/3,408.3)			
	Spindle Type	-	BELT + 3 STEP GEAR			
	Spindle Nose	-	A2-15			
FEED	C-axis Indexing	deg	-	0.001°	-	0.001°
	Travel (X/Z)	mm(in)	500/1,680 (19.7"/66.1")		500/3,280 (19.7"/129.1")	
	Rapid Traverse Rate (X/Z)	m/min(ipm)	12/16 (472/630)		12/12 (472/472)	
TURRET	Slide Type	-	BOX GUIDE			
	No. of Tools	EA	12			
	Tool Size	OD	mm(in)	□ 32 (1.3")		
		ID	mm(in)	Ø80 (3.1")		
Indexing Time	sec/step	0.4				
LIVE TOOL	Motor (Max/Cont.)	kW(HP)	-	11/7.5 (14.8/10)	-	11/7.5 (14.8/10)
	Milling Tool Speed (rpm)	r/min	-	3,000	-	3,000
	Torque (Max/Cont.)	N·m(lbf·ft)	-	140/95.4 (103.3/70.4)	-	140/95.4 (103.3/70.4)
	Collet Size	mm(in)	-	Ø34 (1.3")(ER50)	-	Ø34 (1.3")(ER50)
	Type	-	-	BMT85P	-	BMT85P
TAIL STOCK	Taper	-	MT6 (Built-in)			
	Quill Dia.	mm(in)	Ø160 (6.3")			
	Quill Travel	mm(in)	132.5 (5.2")			
	Travel	mm(in)	1,580 (62.2")		3,180 (125.2")	
TANK CAPACITY	Coolant Tank	ℓ (gal)	570 (150.6)		770 (203.4)	
	Lubricating Tank	ℓ (gal)	4.0 (1.1)			
POWER SUPPLY	Electric Power Supply	kVA	51			
	Thickness of Power Cable	Sq	Over 50			
	Voltage	V/Hz	220/60 (200/50*)			
MACHINE	Floor Space (L×W)	mm(in)	7,077×3,075 (278.6"×121.1")		8,715×3,075 (343.1"×121.1")	
	Height	mm(in)	2,700 (106.3")			
	Weight	kg(lb)	18,000 (3,968)		23,500 (51,809)	
PC	Controller	-	FANUC 32i-A			

\*) Using 50Hz voltage instead of 60Hz may lower the output of motors. (excluding servo motors and inverter motors)

Prior consultation is required when applying spindle contouring control for gear driven spindle.

Specifications are subject to change without notice for improvement.



# SPECIFICATIONS

## Specifications

[ ] : Option

ITEM			L700A	L700MA	L700LA	L700LMA
CAPACITY	Swing Over the Bed	mm(in)	Ø1,050 (41.3")			
	Swing Over the Carriage	mm(in)	Ø820 (32.3")			
	Max. Turning Dia.	mm(in)	Ø920 (36.2")			
	Max. Turning Length	mm(in)	1,650 (65")		3,250 (128")	
	Bar Capacity	mm(in)	Ø165 (6.5")			
SPINDLE	Chuck Size	inch	Opt. [ 24" ]			
	Spindle Bore	mm(in)	Ø181 (7.1")			
	Spindle Speed (rpm)	r/min	1,500			
	Motor (30min./Cont.)	kW(HP)	45/37 (60.3/49.6)			
	Torque (30min./Cont.)	N·m(lbf·ft)	6,928 / 5,700 (5,109.8/4,204.1)			
	Spindle Type	-	BELT+3STEP GEAR			
	Spindle Nose	-	A1-15			
	C-axis Indexing	deg	-	0.001°	-	0.001°
	FEED	Travel (X/Z)	mm(in)	500/1,680 (19.7"/66.1")		500/3,280 (19.7"/129.1")
Rapid Traverse Rate (X/Z)		m/min(ipm)	12/16 (472/630)		12/12 (472/472)	
Slide Type		-	BOX GUIDE			
TURRET	No. of Tools	EA	12			
	Tool Size	OD	Ø32 (1.3")			
		ID	Ø80 (3.1")			
	Indexing Time	sec/step	0.4			
LIVE TOOL	Motor (Max/Cont.)	kW(HP)	-	11/7.5 (14.8/10)	-	11/7.5 (14.8/10)
	Milling Tool Speed (rpm)	r/min	-	3,000	-	3,000
	Torque (Max/Cont.)	N·m(lbf·ft)	-	140/95.4 (103.3/70.4)	-	140/95.4 (103.3/70.4)
	Collet Size	mm(in)	-	Ø34 (1.3")(ER50)	-	Ø34 (1.3")(ER50)
	Type	-	-	BMT85P	-	BMT85P
TAIL STOCK	Taper	-	MT6 (Built-in)			
	Quill Dia.	mm(in)	Ø160 (6.3")			
	Quill Travel	mm(in)	132.5 (5.2")			
	Travel	mm(in)	1,580 (62.2")		3,180 (125.2")	
TANK CAPACITY	Coolant Tank	ℓ (gal)	570 (150.6)		770 (203.4)	
	Lubricating Tank	ℓ (gal)	4.0 (1.1)			
POWER SUPPLY	Electric Power Supply	kVA	51			
	Thickness of Power Cable	Sq	Over 50			
	Voltage	V/Hz	220/60 (200/50*)			
MACHINE	Floor Space (L×W)	mm(in)	7,077×3,075 (278.6"×121.1")		8,715×3,075 (343.1"×121.1")	
	Height	mm(in)	2,700 (106.3")			
	Weight	kg(lb)	18,000 (3,968)		23,500 (51,809)	
PC	Controller	-	FANUC 32i-A			

\*) Using 50Hz voltage instead of 60Hz may lower the output of motors. (excluding servo motors and inverter motors)

Prior consultation is required when applying spindle contouring control for gear driven spindle.

Specifications are subject to change without notice for improvement.

# SPECIFICATIONS

## Specifications

[ ] : Option

ITEM			L800A	L800MA	L800LA	L800LMA
CAPACITY	Swing Over the Bed	mm(in)	Ø1,050 (41.3")			
	Swing Over the Carriage	mm(in)	Ø820 (32.3")			
	Max. Turning Dia.	mm(in)	Ø920 (36.2")			
	Max. Turning Length	mm(in)	1,650 (65")		3,250 (128")	
	Bar Capacity	mm(in)	Hydraulic : Ø239 (9.4"), Air/Independent : Ø319 (12.6")			
SPINDLE	Chuck Size	inch	Opt. [32"]			
	Spindle Bore	mm(in)	Ø320 (12.6")			
	Spindle Speed (rpm)	r/min	700			
	Motor (30min./Cont.)	kW(HP)	45/37 (60.3/49.6)			
	Torque (30min./Cont.)	N·m(lbf·ft)	7,045/5,795 (5,196.1/4,274.2)			
	Spindle Type	-	BELT+2STEP GEAR			
	Spindle Nose	-	A1-20			
	C-axis Indexing	deg	-	0.001°	-	0.001°
FEED	Travel (X/Z)	mm(in)	500/1,680 (19.7"/66.1")		500/3,280 (19.7"/129.1")	
	Rapid Traverse Rate (X/Z)	m/min(ipm)	12/16 (472/630)		12/12 (472/472)	
	Slide Type	-	BOX GUIDE			
TURRET	No. of Tools	EA	12			
	Tool Size	OD	□ 32 (1.3")			
		ID	Ø80 (3.1")			
	Indexing Time	sec/step	0.4			
LIVE TOOL	Motor (Max/Cont.)	kW(HP)	-	11/7.5 (14.8/10)	-	11/7.5 (14.8/10)
	Milling Tool Speed (rpm)	r/min	-	3,000	-	3,000
	Torque (Max/Cont.)	N·m(lbf·ft)	-	140/95.4 (103.3/70.4)	-	140/95.4 (103.3/70.4)
	Collet Size	mm(in)	-	Ø34 (1.3")(ER50)	-	Ø34 (1.3")(ER50)
	Type	-	-	BMT85P	-	BMT85P
TAIL STOCK	Taper	-	MT6 (Built-in)			
	Quill Dia.	mm(in)	Ø160 (6.3")			
	Quill Travel	mm(in)	132.5 (5.2")			
	Travel	mm(in)	1,580 (62.2")		3,180 (125.2")	
TANK CAPACITY	Coolant Tank	ℓ (gal)	570 (150.6)		770 (203.4)	
	Lubricating Tank	ℓ (gal)	4.0 (1.1)			
POWER SUPPLY	Electric Power Supply	kVA	54			
	Thickness of Power Cable	Sq	Over 50			
	Voltage	V/Hz	220/60 (200/50*)			
MACHINE	Floor Space (L×W)	mm(in)	7,077×3,075 (278.6"×121.1")		8,715×3,075 (343.1"×121.1")	
	Height	mm(in)	2,700 (106.3")			
	Weight	kg(lb)	18,000 (3,968)		23,500 (51,809)	
PC	Controller	-	FANUC 32I-A			

\*) Using 50Hz voltage instead of 60Hz may lower the output of motors. (excluding servo motors and inverter motors)

Prior consultation is required when applying spindle contouring control for gear driven spindle.

Specifications are subject to change without notice for improvement.

# SPECIFICATIONS

## Specifications

[ ] : Option

ITEM		L800D	L800MD	L800LD	L800LMD	
CAPACITY	Swing Over the Bed	mm(in)	Ø1,050 (41.3")			
	Swing Over the Carriage	mm(in)	Ø820 (32.3")			
	Max. Turning Dia.	mm(in)	Ø920 (36.2")			
	Max. Turning Length	mm(in)	1,650 (65")	3,250 (128")		
	Bar Capacity	mm(in)	Ø374 (14.7")			
SPINDLE	Chuck Size	inch	Opt. [34" Air Chuck] [32" Independent Chucks]			
	Spindle Bore	mm(in)	Ø375 (14.8")			
	Spindle Speed (rpm)	r/min	500			
	Motor (30min./Cont.)	kW(HP)	45/37 (60.3/49.6)			
	Torque (30min./Cont.)	N·m(lbf·ft)	7,288/5,992 (5,375.4/4,419.5)			
	Spindle Type	-	BELT+2STEP GEAR			
	Spindle Nose	-	A2-20			
	C-axis Indexing	deg	-	0.001°	-	0.001°
	FEED	Travel (X/Z)	mm(in)	500/1,680 (19.7"/66.1")	500/3,280 (19.7"/129.1")	
Rapid Traverse Rate (X/Z)		m/min(ipm)	12/16 (472/630)	12/12 (472/472)		
Slide Type		-	BOX GUIDE			
TURRET	No. of Tools	EA	12			
	Tool Size	OD	mm(in)	Ø 32 (1.3")		
		ID	mm(in)	Ø80 (3.1")		
	Indexing Time	sec/step	0.4			
LIVE TOOL	Motor (Max/Cont.)	kW(HP)	-	11/7.5 (14.8/10)	-	11/7.5 (14.8/10)
	Milling Tool Speed (rpm)	r/min	-	3,000	-	3,000
	Torque (Max/Cont.)	N·m(lbf·ft)	-	140/95.4 (103.3/70.4)	-	140/95.4 (103.3/70.4)
	Collet Size	mm(in)	-	Ø34 (1.3")(ER50)	-	Ø34 (1.3")(ER50)
	Type	-	-	BMT85P	-	BMT85P
TAIL STOCK (OPTION)	Taper	-	MT6 (Built-in)			
	Quill Dia.	mm(in)	Ø160 (6.3")			
	Quill Travel	mm(in)	132.5 (5.2")			
	Travel	mm(in)	1,580 (62.2")	3,180 (125.2")		
TANK CAPACITY	Coolant Tank	ℓ (gal)	570 (150.6)	770 (203.4)		
	Lubricating Tank	ℓ (gal)	4.0 (1.1)			
POWER SUPPLY	Electric Power Supply	kVA	54			
	Thickness of Power Cable	Sq	Over 50			
	Voltage	V/Hz	220/60 (200/50*)			
MACHINE	Floor Space (L×W)	mm(in)	7,077×3,075 (278.6"×121.1")	8,715×3,075 (343.1"×121.1")		
	Height	mm(in)	2,700 (106.3")			
	Weight	kg(lb)	18,000 (3,968)	23,500 (51,809)		
PC	Controller	-	FANUC 32i-A			

\*) Using 50Hz voltage instead of 60Hz may lower the output of motors. (excluding servo motors and inverter motors)

Prior consultation is required when applying spindle contouring control for gear driven spindle.

Specifications are subject to change without notice for improvement.

# CONTROLLER

## FANUC 32i-A

Axis control / Display unit	
Controlled axes	Max. 4 axes are available X, Z axes X, Z, C axes (M type machine) X, Z, Y, C axes (Y type machine) X, Z, B, C axes (MS type machine)
Simultaneous controllable axes	2axes / Linear and circular (Max. 4axes)
Least input increment	X, Z, Y, B axes : 0.001 mm (0.0001") C axis : 0.001 deg
Least command increment	X, Z, Y, B axes : 0.001 mm (0.0001") C axis : 0.001 deg
High speed HRV control	
Inch / Metric conversion	G20 / G21
Interlock	Each axis / All axes
Machine lock	All axes
Emergency stop	
Stored stroke check 1	Over-travel
Stored stroke check 2	
Stored stroke check 3	
Follow-up	
Servo-off	
Backlash compensation	+/- 0~9999 pulses (Rapid traverse & cutting feed)
Position switch	
Unexpected disturbance torque detection	Back-spin torque limiter (BST)
High resolution transfer control (HRM)	
LCD / MDI	10.4" Color LCD
Operation	
Automatic operation (memory)	
MDI operation	
Search function	Sequence, program
Program restart	
Wrong operation prevention	
Buffer register	
Program check function	Dry run., program check
Single block	
Feed functions	
Manual jog feed	Rapid, jog, handle
Manual handle feedrate	x1, x10, x100
Feed command	F code feedrate direct command
Feedrate override	0~200 % (10% units)
Jog override	0~2,000 mm/min[79 ipm]
Rapid traverse override	F1, F5, F25/F50, F100%
Override cancel	
Feed per minute / rotation	
Program input & interpolation functions	
Pano interpolation	Positioning / Linear / Circular (G00 / G01 / G02, G03)
Dwell	G04, 0~9999.9999 sec
Thread retract	
Variable lead threading	
1st reference point return	G28, manual
Reference point return check	G27
2nd reference point return	G30
Program stop / End	M00, M01 / M02, M30
Tape code	EIA / ISO
Optional block skip	1 ea
Maximum programmable dimensions	+/- 9999.9999"
Program number	0+4 digits
Absolute and incremental programming	
Decimal point input	
Plane selection	G17, G18, G19
Work coordinate system selection	G52 to G59
Manual absolute	"ON" Fixed
G code system	A
Programmable data input	G10
Sub program call	10 folds nested
Custom macro B	

Program input & interpolation functions	
Addition of custom macro common variable	#100 to #199, #500 to #999
Multiple repetitive cycles	
Multiple repetitive cycles II	
Canned cycles for turning	
Manual guide i	Conversational programming
Sub / Main spindle function	
M-Code function	M4 digits
M-Code function lock	
Lock sp. speed command	S4 digits, binary output
Main sp. constant control	G96, G97
Spindle speed override	50% to 150% (10% units)
Spindle position decision	
Rigid tapping	
Tool function / Tool compensation	
Tool function	T2 + 2
Tool offset pairs	64 pairs
Tool offset	
Tool nose radius compensation	G40, G41, G42
Direct input of measured tool compensation value B	
Tool life management	
Data in/output & editing functions	
Reader / Puncher interface	RS232C
Memory card input/output	
Part program storage length	256 Kbyte
Number of registrable programs expansion	Max. 500 programs
Memory lock	
Background editing	
Extended part program edition	Copy, move, change of NC program
Display, diagnosis & setting functions	
Self-diagnosis function	
History display	Alarm & operation display
Help function	
External message	
Run hour / Parts count display	
Display of actual spindle speed and T code	
Actual cutting feedrate display	
Operating monitor screen	Rod meter light
Graphic display	
Spindle / Servo setting screen	
Selection of 5 optional language	
LCD screen display	Screen saver
Automatic data backup	
Functions according to machine specification	
Cs contouring control	Turn mill
Stored pitch error compensation	Turn mill
Polar coordinate interpolation	Turn mill
Cylindrical interpolation	Turn mill
Canned cycles for drilling	Turn mill
spindle orientation expansion	Turn mill, Sub spindle
Spindle synchronous control	Sub spindle
Torque control	Sub spindle
Y axis offset	Y type machine
Angular axis control	Y type machine
Option	
High speed Ethernet	100 Mbps (Option board is required)
Optional block skip	9 ea
3rd & 4th reference point return	
G code system	B / C
Part program storage length	512 Kbyte
Polygon turning	
Helical interpolation	
Dynamic graphic display	
Protection of data at 8 levels	
Direct drawing dimension programming	Included chamfering / Corner R'

Figures in inch are converted from metric values.

The FANUC controller specifications are subject to change based on the policy of company CNC supplying.

# GLOBAL NETWORK



## HEADQUARTER

### Changwon Technical Center / R&D Center / Factory

153, Jeongdong-ro, Seongsan-gu, Changwon-si,  
Gyeongsangnam-do, Korea (Zip Code : 51533)  
TEL : +82 55 280 9114 FAX : +82 55 282 9680

### Uiwang Technical Center / R&D Center

37, Cheoldobangmulgwan-ro, Uiwang-si, Gyeonggi-do,  
Korea (Zip Code : 16082)  
TEL : +82 31 596 8209 Fax : +82 55 210 9804

## OVERSEAS OFFICES

### HYUNDAI WIA Machine Tools America

265, Spring Lake Drive, Itasca, IL, 60143  
TEL : +1 630 625 5600  
FAX : +1 630 625 4733

### Jiangsu HYUNDAI WIA

Company No.6 Fenghuang Road,  
Fenghuang Town, Zhangjiagang City,  
Jiangsu province, China  
TEL : +86 512 5672 6808  
FAX : +86 512 5671 6960

### Chengdu Branch Office

NO.508 Room, B Block, AFC Plaza, NO.88  
Jiaozi Road, High-tech Zone, Chengdu,  
China  
TEL : +86 028 8665 2985  
FAX : +86 028 8665 2985

### HYUNDAI WIA Machine Tools Europe

Kaiserleipromenade 5, 63067 Offenbach,  
Germany  
TEL : +49 69271 472 701  
FAX : +49 69271 472 719

### Hyundai WIA Machine Tools China Shanghai Branch Office

1-3F, Bldg6, No.1535 Hongmei Road,  
Xuhui District, Shanghai, China  
TEL : +86 021 6427 9885  
FAX : +86 021 6427 9890

### Qingdao Branch Office

Room 1207, Cai Fu Building, 182-6 Haier  
Middle Road, Qingdao, China  
TEL : +86 532 8667 9334  
FAX : +86 532 8667 9338

### Raunheim Service Center Raunheim R&D Center

Frankfurter. 63, 65479 Raunheim,  
Germany  
TEL : +49 6142 9256 111  
FAX : +49 6142 9256 100

### Beijing Branch Office

Floor 14, Zhonghangji Plaza B, No.15  
Ronghua South Road, BDA Dist., Daxing  
Dist., Beijing, China 100176  
TEL : +86 010 8453 9850  
FAX : +86 010 8453 9853

### Wuhan Office

306-2, A Tower, Jiayu Gpmggian, No12  
Chuangye Road, Economic Development  
Zone, Wuhan, Hubei, China  
TEL : +86 027 5952 3256  
FAX : +86 027 5952 3256

### India Branch Office

#4/169, Rajiv Gandhi Salai, (OMR),  
Kandanchavadi, Chennai-600 096,  
Tamilnadu, India  
TEL: +91-44-3290-1719

### Guangzhou Branch Office

Room 311, Unit 1-3, POLY TAL TU WUP,  
Hanxi Avenue, Panyu District, Guangzhou,  
China  
TEL : +86 020 8550 6595  
FAX : +86 020 8550 6597

### Chongqing Office

Room 951, #3, Jinrongcheng T3, Jiangbei,  
Chongqing, China  
TEL : +86 23 6701 2970

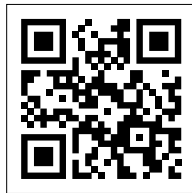

L700A Movie

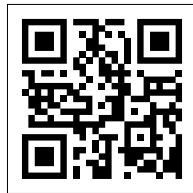

L800D Movie 1

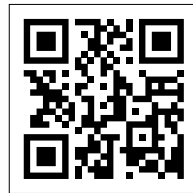

L800D Movie 2

# www.wardcnc.com



<http://machine.hyundai-wia.com>

---

#### Head Office & Factory

153, Jeongdong-ro, Seongsan-gu, Changwon-si, Gyeongsangnam-do Tel +82 55 280 9500

#### Overseas Sales Team

16F, 37, Cheoldobangmulgwan-ro, Uiwang-si, Gyeonggi-do Tel +82 31 593 8173

---

#### HYUNDAI WIA Machine Tools America

265 Spring Lake Drive, Itasca, IL, 60143 Tel +1 (630) 625 5600 Fax +1 (630) 625 4733

#### HYUNDAI WIA Machine Tools Europe

Kaiserleipromenade 5, D-63067 Offenbach, Germany Tel +49 69271 472 701 Fax +49 69271 472 719

#### India Branch Office

#4/169, Rajiv Gandhi Salai, (OMR), Kandanchavadi, Chennai-600 096, Tamilnadu, India Tel +91 44 3290 1719

---