

L-SY Series

HYUNDAI WIA Multi-Tasking Y-Axis CNC Turning Center

www.wardcnc.com



Technical Leader

The CNC Turning Center L-SY Series, designed with HYUNDAI WIA's engineering expertise to maximize productivity by enhancing rigidity and accuracy of machining.



www.wardcnc.com

ITEM	Main Chuck			Sub Chuck	Bed		
	8"	10"	12"	6"	Short	Standard	Long
L2000Y	•				•		
L2000SY	•			•	•		
L2000LY	•					•	
L2000LSY	•			•		•	
L2600Y		•				•	
L2600SY		•		•		•	
L2600LY		•					•
L3000Y			•			•	
L3000SY			•	•		•	
L3000LY			•				•

Y-Axis with Box Guideways Lathe for
Heavy-Duty Cutting

L-SY Series

- Cycle time reducing structure for maximum productivity
- Multi-tasking operation with wedge type Y-axis BMT65P turret
- Integrated processing through synchronized control of Main/Sub spindle
- High performance heavy duty cutting enabled with box guideways
- Main/Sub Built-in Spindle application for high precision processing



01

L-SY Series

Basic Structure

Covers All Machining Process
with Only One Initial Setting

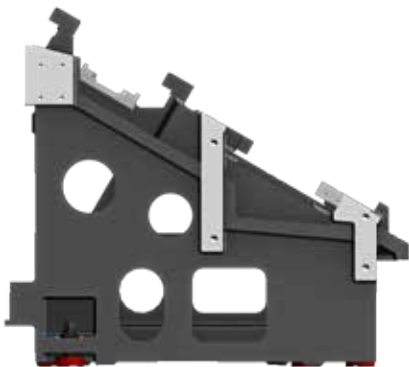

01

30° Slant Type Bed

The one-piece 30° slant bed design is based on FEM analysis which provides improvement in vibration absorption and machining stability during heavy duty cutting.

Box Guideway

All axis of L-SY Series are designed with Box Guideways for better travel ability. Box Guideways show great performance in offsetting vibrations caused by heavy duty cutting.



02

Main Built-In Spindle

Heat produced by the main spindle is blocked by applying a symmetric one-piece base and an insulation plate. This enables maintaining high accuracy even during a long period of machining.



03

BMT Turret (BMT65P)

The BMT holder is firmly fixed with 4 screws keeping it in place during heavy operations, especially during milling, drilling, and tapping.



04

6" Sub Spindle ("S" Type)

The sub spindle is equipped with built-in motor and headstock cooling device as standard to minimize thermal displacement.

Also, the use of use of a sub spindle reduces setup time, improving productivity.

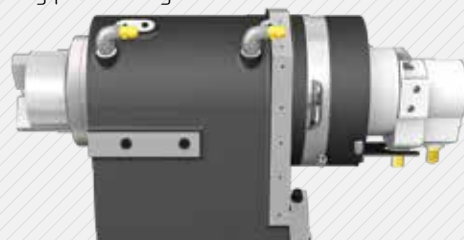

05

Basic Structure

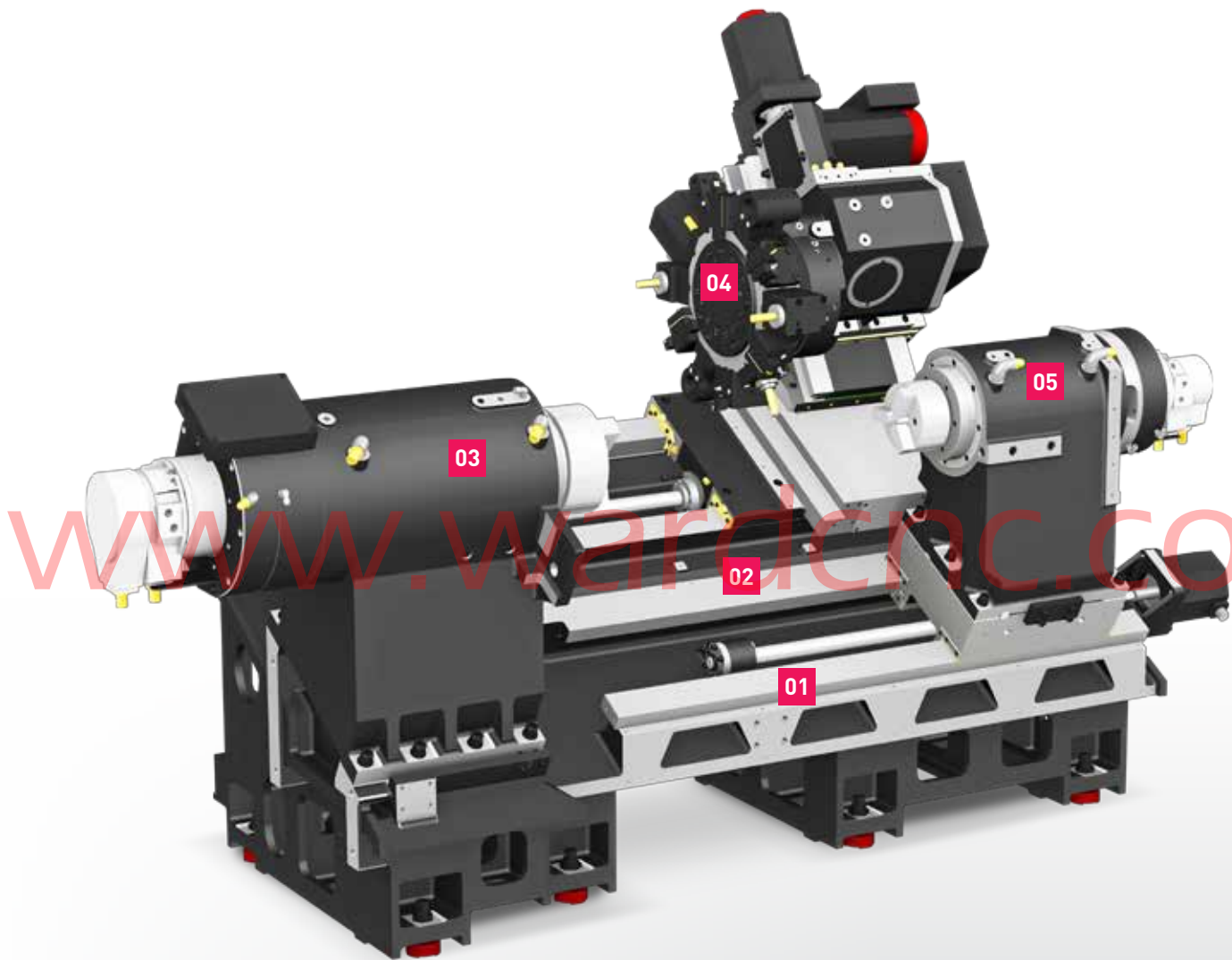

Reduction of Non-Cutting Time

⦿ **Travel** (X/Y/Z/ZB)

L2000Y/SY : 265/120{±60}/590/590 mm (10.4"/4.7" {±2.4"}/23.2"/23.2")

L2000LY/LSY, L2600Y/SY, L3000Y/SY : 265/120{±60}/830/830 mm (10.4"/4.7" {±2.4"}/32.7"/32.7")

L2600LY, L3000LY : 265/120{±60}/1,350 mm (10.4"/4.7" {±2.4"}/53.1")

⦿ **Rapid Traverse Rate** (X/Y/Z/ZB) : 30/10/30/30 m/min (1,181/294/1,181/1,181 ipm)

02

L-SY Series

Built-in Spindle

Long Lasting High Accuracy & Excellent Performance
CNC Turning Center



www.wardcnc.com

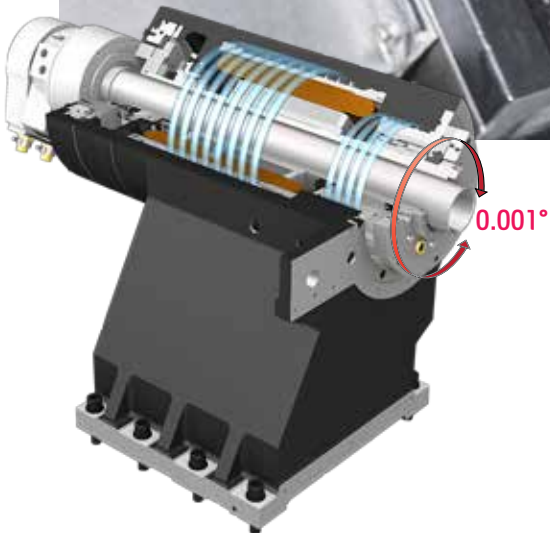

Built-In Main Spindle

Built-in type spindle reduces noise, heat and vibration effectively at high speed rates. Also, rapid acc./deceleration reduces non-cutting time leading to higher productivity.

C-Axis Control

C-axis control of main and sub spindle allows machining of various products with the use of live tools on the Y-axis.

Built-In Sub Spindle

The "S" Type built-in sub-spindle has **6" sub-chuck**, which enlarges the machining area and improves the workability of the sub spindle with the C-axis control.

◎ Bar Capacity : Ø51 (Ø2")

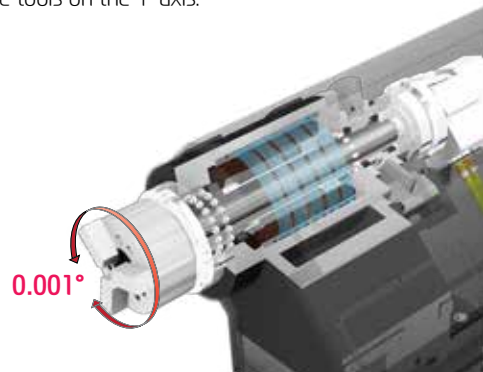

L2000 Built-in Main Spindle

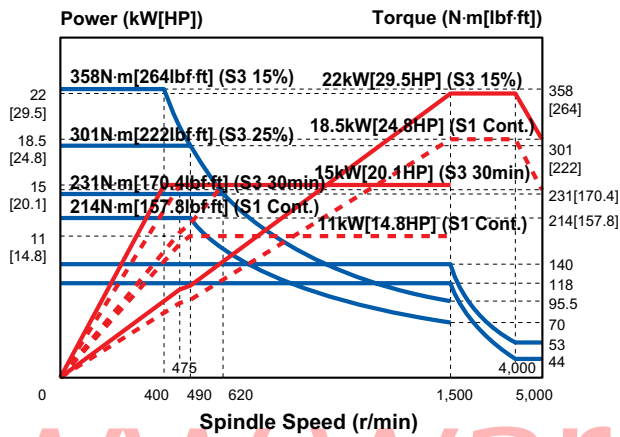

L2600 Built-in Main Spindle

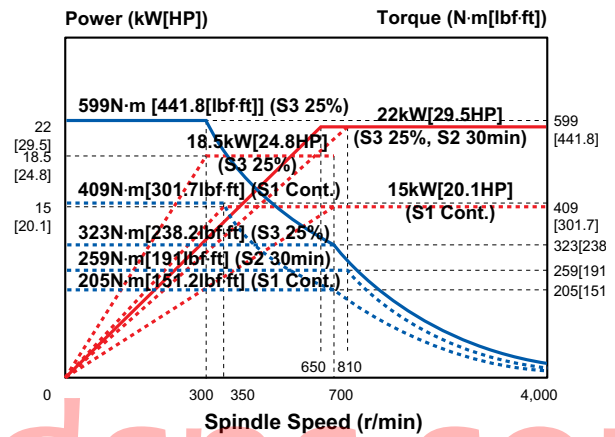

L3000 Built-in Main Spindle

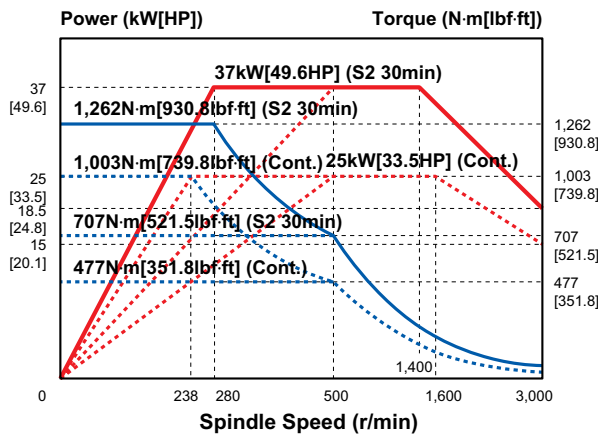

Built-in Sub Spindle

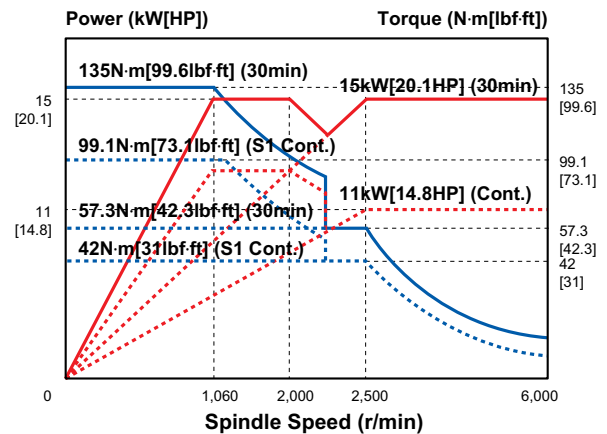

L2000 : 5,000rpm (Built-in)

L2600 : 4,000rpm (Built-in)

L3000 : 3,000rpm (Built-in)

Sub Sp. : 6,000rpm (Built-in)

22 kW (29.5 HP)
Max. Output

22 kW (29.5 HP)
Max. Output

37 kW (49.6 HP)
Max. Output

15 kW (20.1 HP)
Max. Output

358 N·m (264 lbf·ft)
Max. Torque

599 N·m (441.8 lbf·ft)
Max. Torque

1,262 N·m (930.8 lbf·ft)
Max. Torque

135 N·m (99.6 lbf·ft)
Max. Torque

www.wardcnc.com

03

L-SY Series

Belt Type Spindle



Long Lasting, High Accuracy & Excellent Performance
CNC Turning Center



www.wardcnc.com

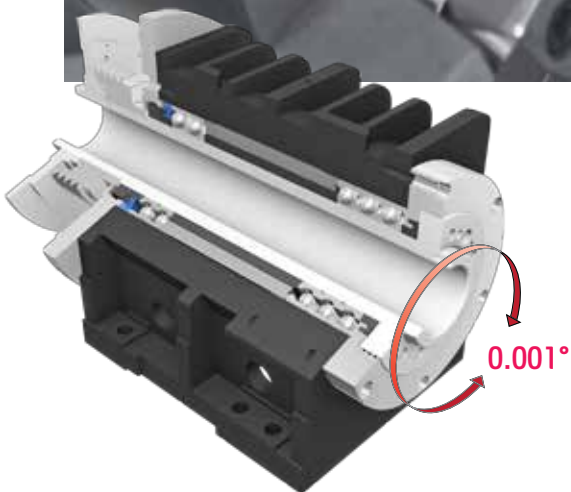

Belt Type Main Spindle

Belt type main spindle has a wide torque range and it is designed to minimize thermal displacement. This enables accurate machining during high speed constant processing.

C-Axis Control

C-axis control of main and sub spindle allows machining of various products with the use of live tools on the Y-axis.

Belt Type Sub Spindle

The belt-type sub spindle with 6" chuck is designed to minimize thermal displacement during long duration continuous machining and from heavy-duty cutting to high-speed processing.

◎ Bar Capacity : Ø51 (Ø2")



L2000 Belt Main Spindle

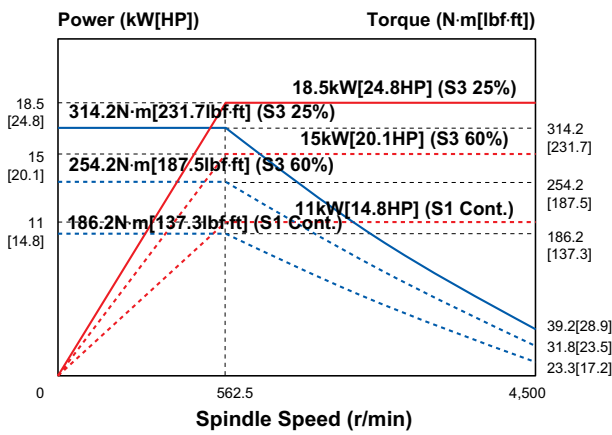

L2600 Belt Main Spindle

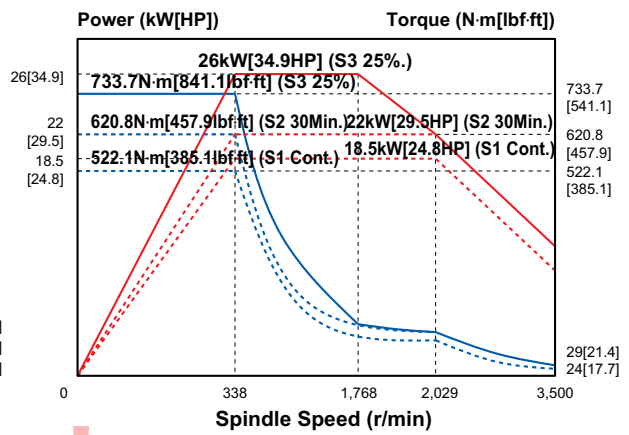

L3000 Belt Main Spindle

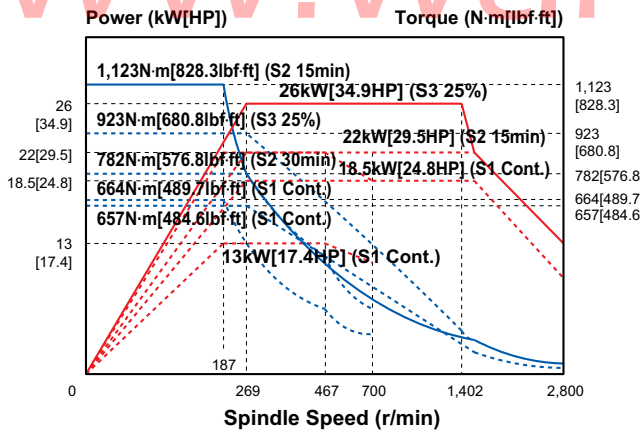

Belt Sub Spindle

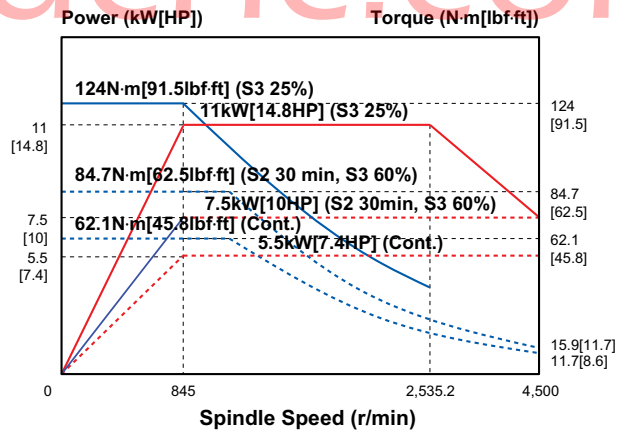

L2000 : 4,500rpm (Belt)

L2600 : 3,500rpm (Belt)

L3000 : 2,800rpm (Belt)

Sub : 4,500rpm (Belt)

18.5 kW (24.8 HP)
Max. Output

26 kW (34.9 HP)
Max. Output

26 kW (34.9 HP)
Max. Output

11 kW (14.8 HP)
Max. Output

314.2 N·m (231.7 lbf-ft)
Max. Torque

733.7 N·m (541.1 lbf-ft)
Max. Torque

1,123 N·m (828.3 lbf-ft)
Max. Torque

124 N·m (91.5 lbf-ft)
Max. Torque

www.wardcnc.com

04

L-SY Series

Y-Axis Function

High speed, High Accuracy, Highly Reliable
BMT Turret



www.wardcnc.com

Wedge Type Y-axis Structure

The L2000SY/2600SY/3000SY is designed with a wedge type Y-axis that is transferred by the simultaneous operation of the Ys-axis and the X-axis. In addition, excellent rigidity makes possible to perform superb quality when machining a heavy-duty cutting.

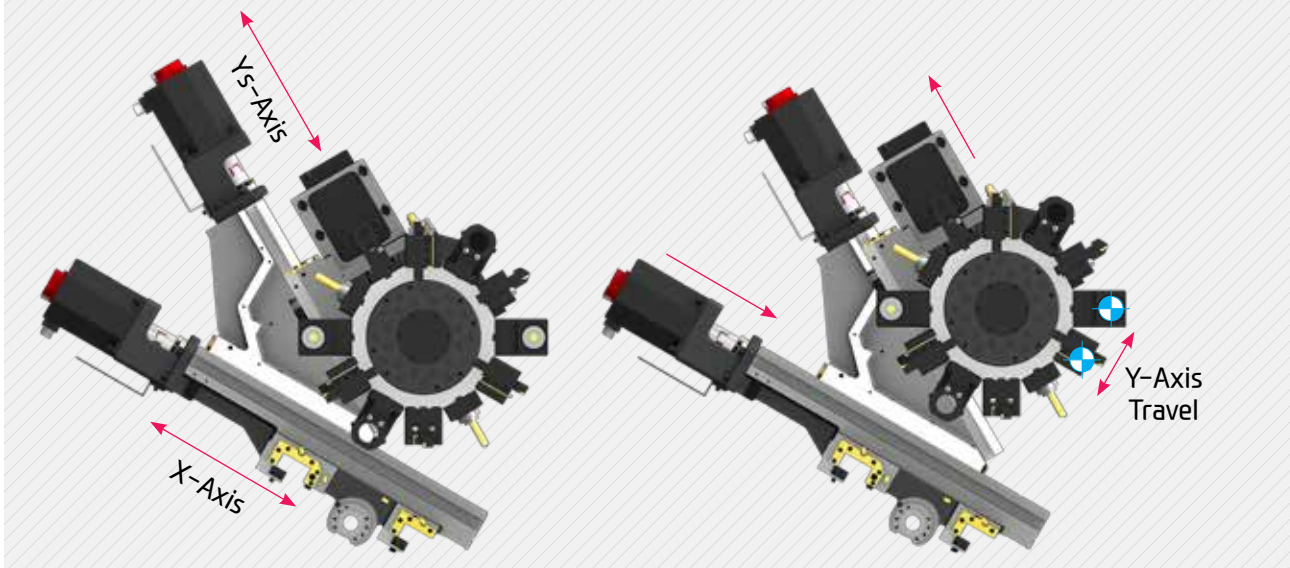

Mill Turret (BMT65P)

The BMT turret secures the tool with four bolts and key on the tool mounting surface of the turret, making it possible to powerfully fix the tool, ensuring high reliability in rigidity and precision.



- ⦿ Output(Max./Cont.) : 5.5/1.5 kW (7.4/2 HP)
- ⦿ Speed : 5,000 r/min
- ⦿ Collet size : Ø25 (Ø1") (ER32)
- ⦿ Live Tool Type : BMT65P
- ⦿ Indexing Time : 0.15 sec/step

Straight Milling Head



Angular Milling Head



Mill Tool Holder

Machining capability has increased with the addition of straight milling head tool holder, which can machine workpieces from the side, and angular milling head tool holder, which can perform I.D. operations.



Mill Spindle

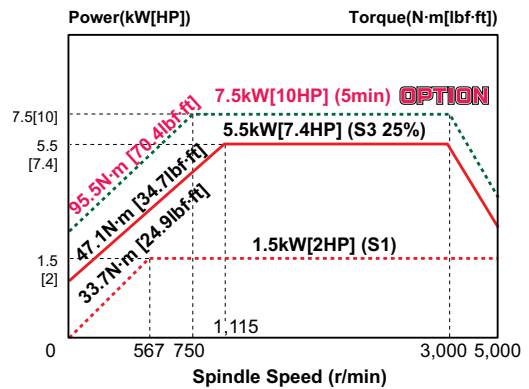

05

L-SY Series

Special Tool Holders

Various Driven Precision Tool Holders for
CNC Turning Centers



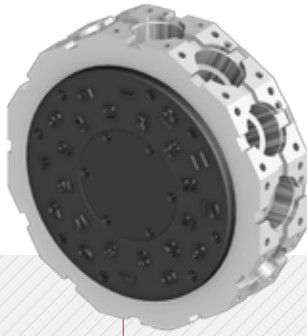

Tooling System

With the Y-axis, the L-SY series can process high value-added products using a variety of rotating tools. In particular, there is a multi-holder for attaching a variety of tools to one holder, and an eccentric rotary tool for handling eccentric parts without additional axis travel, which can realize integration of process with one machine.



❖ Consultation needed when ordering these options.

n6
L-SY Series

Smart System



Software for Smart Operating
and Machining

Faster processing and enhanced accuracy in are possible through the **HYUNDAI WIA Smart System**. The user friendly software and equipment monitoring of the Smart System maximizes productivity.

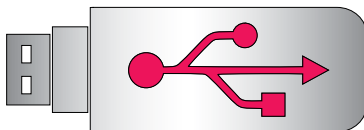
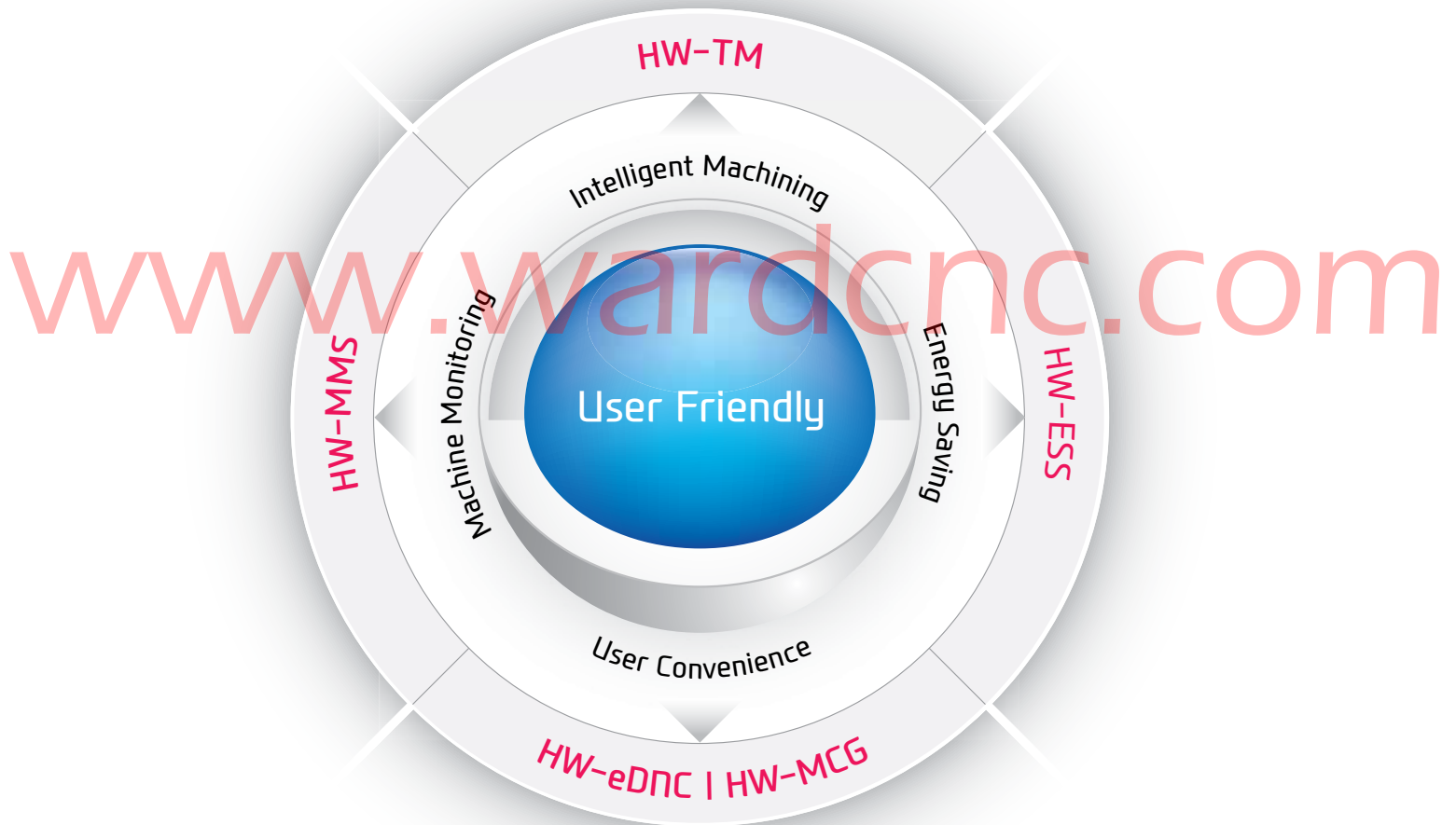

USB Port (Standard)

Convenience is increased when inputting and outputting program. The USB port is available in addition to the former input output methods such as CF memort card and LAN.

Smart Factory HW-MMS (HYUNDAI WIA-Machine Monitoring System)

A brand new manufacturing machine by HYUNDAI WIA, HW-MMS is a unique software capable of monitoring the operation status of manufacturing machines in factories, a smart solution to improve manufacturing conditions of customers.



- 01 Real-time monitoring of machine operation status (Cloud)
- 02 History and statistics of machine operation (Cloud)
- 03 History and statistics of alarm occurrence (Cloud)
- 04 History and statistics of work count (Cloud)
- 05 Remote diagnosis (Remote)



HW-eDNC
HYUNDAI WIA ethernet
Direct Numerical Control

This software allows transmission of NC data between PC and a machine's CNC. The processing programs can be managed on the PC through the ethernet or serial communication.



HW-MCG
HYUNDAI WIA
Machine Guidance

Software that offers operation, maintenance, management monitoring and various user friendly features.



HW-TM
HYUNDAI WIA
Tool Monitoring

A tool monitoring software which analyzes the load of the spindle motor to determine and monitor possible damage of tools.



HW-ESS (Standard)
HYUNDAI WIA
Energy Saving System

An environmental friendly software that reduces the unnecessarily wasted standby power waiting for an operation.

07

L-SY Series

User Convenience

Various Devices for User Friendly

Automatic Q-Setter

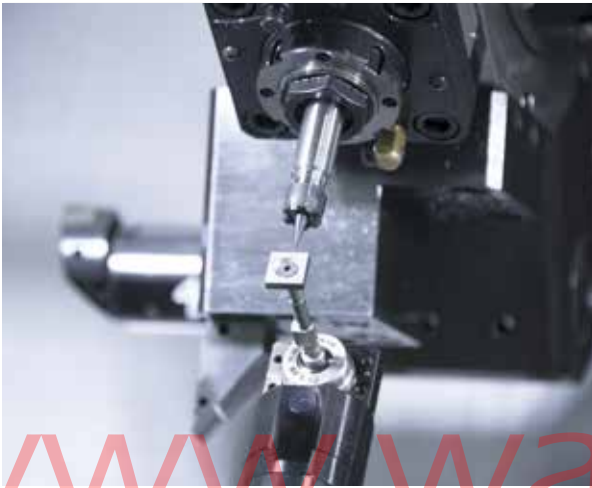

Quick and accurate tool calibration can be done by contacting the tool tip with the sensor. This process is done easily with the use of M-Code and the calibration process takes roughly 30 seconds.

Precision Device **OPTION**

Linear Scale

Linear scale and rotary scale help process highly accurate products through precise locating.



Tail Stock

- The large (MT#5) tail stock ensures high accuracy during heavy duty cutting.
- The quill movement can be controlled by foot pedal or program.
- The body can be moved by connecting to the saddle and using the JOG button or MPG.

Type : **Quill** Quill Travel : **120mm (4.7")**

Quill Dia. : **Ø100 (3.9")**



NC Tail Stock **OPTION**

NC tail stock can be moved separately, providing convenience during workpiece setup.

Programmable + Live Center (MT#5) + Quill	Std.
Programmable + Dead Center (MT#4) + Quill	Opt.
NC Feed + Live Center (MT#5)	Opt.
NC Feed + Dead Center (MT#4)	Opt.

Optional

Bar Feeder System **OPTION**

Bar Feeder

Bar feeder system enables automation which leads to efficiency improvement.

Long Type	3 m (118.1")
Max Bar Capacity	Ø42 mm (1.7")
Short Type	1.5 m (59.1")
Max Bar Capacity	Ø65 mm (2.6")

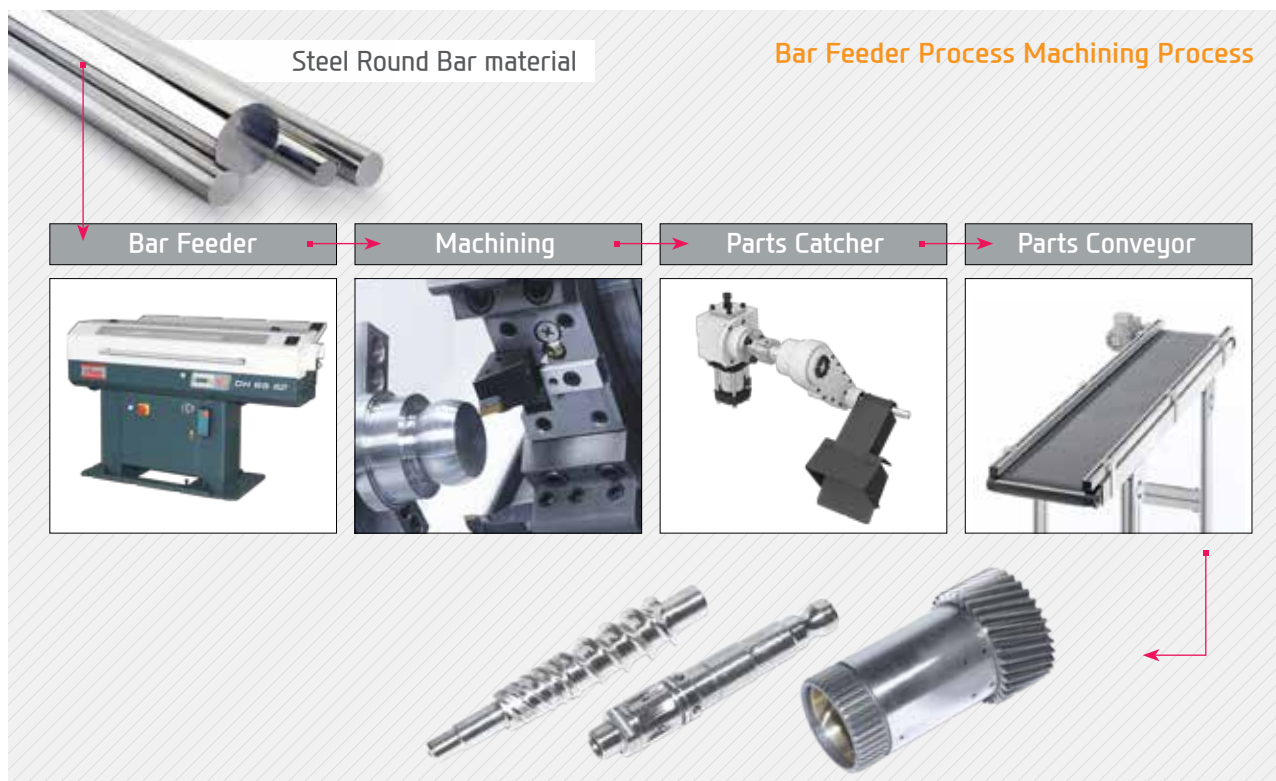

SPECIFICATIONS

Standard & Optional

Spindle		L2000Y/LY	L2000SY/LSY
Main Spindle Hollow Chuck 3 Jaw	8"	●	●
Main Spindle Solid Chuck 3 Jaw	8"	☆	☆
Sub Spindle Hollow Chuck 3 Jaw	6"	-	●
Sub Spindle Solid Chuck 3 Jaw	6"	-	☆
Standard Soft Jaw (1set)		●	●
Chuck Clamp Foot Switch		●	●
2 Steps Hyd. Pressure Device		○	○
Spindle Inside Stopper		☆	☆
5" Index		☆	☆
Cs-Axis (0.001")		●	●
2 Steps Chuck Foot Switch		○	○
Chuck Open/Close Confirmation Device		○ (CE:●)	○ (CE:●)
Sub Spindle Foot Switch		-	●
Turret			
Tool Holder		●	●
Mill Turret	BMT	●	●
Straight Milling Head (Radial)	Collet Type,2ea	●	●
Angular Milling Head (Axial)	Collet Type,2ea	●	●
Straight Milling Head (Radial)	Adapter Type	○	○
Angular Milling Head (Axial)	Adapter Type	○	○
Boring Sleeve		●	●
Drill Socket		●	●
U-Drill Holder		○	○
U-Drill Holder Sleeve		○	○
O.D Extension Holder	For Out-Dia	☆	☆
Angle Head		☆	☆
Tail Stock & Steady Rest			
Manual + Quill Tail Stock		●	-
Programmable + Quill Tail Stock(MT#5)		○	-
Programmable + Built-in Tail Stock(MT#4)		○	-
TC Feed + Quill Tail Stock(MT#5)		○	-
TC Feed + Built-in Tail Stock(MT#4)		○	-
Manual Hyd. Steady Rest (SMW/Khan/Shinkang/Samchully)		☆	☆
Programmable Hyd. Steady Rest		○/☆	○/☆
Standard Live Center		●	-
High Precision Live Center		○	-
2 Steps Tail Stock Pressure System		☆	-
Tail Stock Foot Switch (When Tail Stock is selected)		●	-
Quill Forward/Reverse Confirmation Device		○	-
Coolant & Air Blow			
Standard Coolant (Nozzle)		●	●
Chuck Coolant (Upper Chuck)		○	○
Gun Coolant		○	○
Through Spindle Coolant (Only for Special Chuck)		☆	☆
Turnmill Through Coolant		-	-
Chuck Air Blow (Upper Chuck)		○	○
Sub Spindle Air Blow		-	○
Tail Stock Air Blow (Upper Tail Stock)		☆	-
Turret Air Blow		☆	☆
Air Gun		○	○
Through Spindle Air Blow (Only for Special Chuck)		☆	☆
High Pressure Coolant	1.5Bar (21.8psi)	●	●
	6Bar (87psi)	○	○
	20Bar (290psi)	○	○
	70Bar (1.015psi)	○	○
Power Coolant System (For Automation)		☆	☆
Coolant Chiller (When selecting Sub Tank Type, Chip Conveyor)		☆	☆
Chip Disposal			
Coolant Tank	275 ℓ (72.6 gal) 290 ℓ (76.6 gal)	●/- -/-●	●/- -/-●
Chip Conveyor (Hinge/Scraper)	Front (Right) Rear (Rear)	○ ○	○ ○
Special Chip Conveyor (Drum Filter)		☆	☆

● : Standard ○ : Option ☆ : Prior Consultation - : Non Applicable

Chip Disposal		L2000Y/LY	L2000SY/LSY
Chip Wagon	Standard (180 ℓ [47.5 gal])	○	○
	Swing (200 ℓ [52.8 gal])	○	○
	Large Swing (290 ℓ [76.6 gal])	○	○
	Large Size (330 ℓ [87.2 gal])	○	○
	Customized	☆	☆
Safety Device			
Total Splash Guard		●	●
Chuck hydraulic pressure maintenance interlock		○ (CE:●)	○ (CE:●)
Electric Device			
Call Light	1Color : ●	●	●
Call Light	2Color : ● ●	○	○
Call Light	3Color : ● ● ●	○	○
Call Light & Buzzer	3Color : ● ● ● B	○	○
Electric Cabinet Light		○	○
Remote MPG		-	-
Work Counter	Digital	○	○
Total Counter	Digital	○	○
Tool Counter	Digital	○	○
Multi Tool Counter	Digital	○	○
Electric Circuit Breaker		○	○
AVR (Auto Voltage Regulator)		☆	☆
Transformer	40kVA 60kVA	○ -	- ○
Auto Power Off		○	○
Measurement			
Manual Q-Setter		-	-
Automatic Q-Setter		●	●
Work Close Confirmation Device (TACO (Only for Special Chuck))	SMC	○	○
Work Setter		☆	☆
Linear Scale	X axis	☆	☆
	Z axis	☆	☆
Coolant Level Sensor (Only for Chip Conveyor)		☆	☆
Environment			
Air Conditioner		○	○
Oil Mist Collector		☆	☆
Oil Skimmer (Only for Chip Conveyor)		○	○
MLQ (Minimal Quantity Lubrication)		☆	☆
Fixture & Automation			
Auto Door	High Speed	○	○
Auto Shutter (Only for Automatic System)		☆	☆
Sub Operation Pannel		☆	☆
Bar Feeder Interface		○	○
Bar Feeder (FEDEK)		☆	☆
Sub Sp. Work Eject (Pneumatic Type)		-	○
Sub Sp. Work Pusher (Spring Type)		-	○
Turret Work Pusher (For Automation)		☆	☆
Extra M-Code 4ea		○	○
Automation Interface		☆	☆
I/O Extension (IN & OUT)	16 Contact	○	○
	32 Contact	○	○
Parts Catcher	Main SP.	○	○
	Sub SP.	-	○
Parts Conveyor(Need to Main Part Catcher)		☆	☆
Front Loading Semi Automation		☆	☆
Hyd. Device			
Standard Hyd. Cylinder	Hollow	●	●
Standard Hyd. Unit	35bar(507.6psi) / 14 ℓ (3.7gal)	●	●
S/W			
Machine Guidance (HW-MCG)		☆	☆
Energy Saving System (HW-ESS)		●	●
Tool Monitoring (HW-TM)		○	○
DNC software (HW-eDNC)		○	○
Machine Monitoring System (HW-MMS)		☆	☆
Conversational program (HW-DPRO)		-	-
ETC			
Tool Box		●	●
Customized Color	Need Munsell No.	☆	☆
CAD & CAM		☆	☆

SPECIFICATIONS

Standard & Optional

Spindle		L2600Y/LY	L2600SY
Main Spindle			
Hollow Chuck 3 Jaw	10"	●	●
Main Spindle			
Solid Chuck 3 Jaw	10"	☆	☆
Sub Spindle			
Hollow Chuck 3 Jaw	6"	-	●
Sub Spindle			
Solid Chuck 3 Jaw	6"	-	☆
Standard Soft Jaw (1set)		●	●
Chuck Clamp Foot Switch		●	●
2 Steps Hyd. Pressure Device		○	○
Spindle Inside Stopper		☆	☆
5° Index		☆	☆
Cs-Axis (0.001°)		●	●
2 Steps Chuck Foot Switch		○	○
Chuck Open/Close Confirmation Device		○(CE:●)	○(CE:●)
Sub Spindle Foot Switch		-	●
Turret			
Tool Holder		●	●
Mill Turret	BMT	●	●
Straight Milling Head (Radial)	Collet Type,2ea	●	●
Angular Milling Head (Axial)	Collet Type,2ea	●	●
Straight Milling Head (Radial)	Adapter Type	○	○
Angular Milling Head (Axial)	Adapter Type	○	○
Boring Sleeve		●	●
Drill Socket		●	●
U-Drill Holder		○	○
U-Drill Holder Sleeve		○	○
O.D Extension Holder	For Out-Dia	☆	☆
Angle Head		☆	☆
Tail Stock & Steady Rest			
Manual + Quill Tail Stock		●	-
Programmable + Quill Tail Stock(MT#5)		○	-
Programmable + Built-in Tail Stock(MT#4)		○	-
PC Feed + Quill Tail Stock(MT#5)		○	-
PC Feed + Built-in Tail Stock(MT#4)		○	-
Manual Hyd. Steady Rest (SMW/Khan/Shinkang/Samchully)		☆	☆
Programmable Hyd. Steady Rest		○/☆	☆
Standard Live Center		●	-
High Precision Live Center		○	-
2 Steps Tail Stock Pressure System		☆	-
Tail Stock Foot Switch (When Tail Stock is selected)		●	-
Quill Forward/Reverse Confirmation Device		○	-
Coolant & Air Blow			
Standard Coolant (Nozzle)		●	●
Chuck Coolant (Upper Chuck)		○	○
Gun Coolant		○	○
Through Spindle Coolant (Only for Special Chuck)		☆	☆
Turmill Through Coolant		-	-
Chuck Air Blow (Upper Chuck)		○	○
Sub Spindle Air Blow		-	○
Tail Stock Air Blow (Upper Tail Stock)		☆	-
Turret Air Blow		☆	☆
Air Gun		○	○
Through Spindle Air Blow (Only for Special Chuck)		☆	☆
High Pressure Coolant	1.5Bar (21.8psi)	●	●
	6Bar (87psi)	○	○
	20Bar (290psi)	○	○
	70Bar (1,015psi)	○	○
Power Coolant System (For Automation)		☆	☆
Coolant Chiller (When selecting Sub Tank Type, Chip Conveyor)		☆	☆
Chip Disposal			
Coolant Tank	290 ℓ (76.6 gal)	●/-	●
	320 ℓ (84.5 gal)	-/●	-
Chip Conveyor (Hinge/Scraper)	Front (Right)	○	○
	Rear (Rear)	○	○
Special Chip Conveyor (Drum Filter)		☆	☆

● : Standard ○ : Option ☆ : Prior Consultation - : Non Applicable

Chip Disposal		L2600Y/LY	L2600SY
Chip Wagon	Standard (180 ℓ [47.5 gal])	○	○
	Swing (200 ℓ [52.8 gal])	○	○
	Large Swing (290 ℓ [76.6 gal])	○	○
	Large Size (330 ℓ [87.2 gal])	○	○
Customized	☆	☆	
Safety Device			
Total Splash Guard		●	●
Chuck hydraulic pressure maintenance interlock		○(CE:●)	○(CE:●)
Electric Device			
Call Light	1Color : ●	●	●
Call Light	2Color : ●●	○	○
Call Light	3Color : ●●●	○	○
Call Light & Buzzer	3Color : ●●● B	○	○
Electric Cabinet Light		○	○
Remote MPG		-	-
Work Counter	Digital	○	○
Total Counter	Digital	○	○
Tool Counter	Digital	○	○
Multi Tool Counter	Digital	○	○
Electric Circuit Breaker		○	○
AVR (Auto Voltage Regulator)		☆	☆
Transformer	40KVA	○	-
	60KVA	-	○
Auto Power Off		○	○
Measurement			
Manual Q-Setter		-	-
Automatic Q-Setter		●	●
Work Close Confirmation Device	TACO	○	○
(Only for Special Chuck)	SMC	○	○
Work Setter		☆	☆
Linear Scale	X axis	☆	☆
	Z axis	☆	☆
Coolant Level Sensor (Only for Chip Conveyor)		☆	☆
Environment			
Air Conditioner		○	○
Oil Mist Collector		☆	☆
Oil Skimmer (Only for Chip Conveyor)		○	○
MQL (Minimal Quantity Lubrication)		☆	☆
Fixture & Automation			
Auto Door	High Speed	○	○
Auto Shutter (Only for Automatic System)		☆	☆
Sub Operation Pannel		☆	☆
Bar Feeder Interface		○	○
Bar Feeder (FEDEK)		☆	☆
Sub Sp. Work Eject (Pneumatic Type)		-	○
Sub Sp. Work Pusher (Spring Type)		-	○
Turret Work Pusher (For Automation)		☆	☆
Extra M-Code 4ea		○	○
Automation Interface		☆	☆
I/O Extension (IN & OUT)	16 Contact	○	○
	32 Contact	○	○
Parts Catcher	Main SP.	○	○
	Sub SP.	-	○
Parts Conveyor(Need to Main Part Catcher)		☆	☆
Front Loading Semi Automation		☆	☆
Hyd. Device			
Standard Hyd. Cylinder	Hollow	●	●
Standard Hyd. Unit	35bar(507.6psi) / 14 ℓ (3.7gal)	●	●
S/W			
Machine Guidance (HW-MCG)		☆	☆
Energy Saving System (HW-ESS)		●	●
Tool Monitoring (HW-TM)		○	○
DNC software (HW-eDNC)		○	○
Machine Monitoring System (HW-MMS)		☆	☆
Conversational program (HW-DPRO)		-	-
ETC			
Tool Box		●	●
Customized Color	Need Munsel No.	☆	☆
CAD & CAM		☆	☆

Specifications are subject to change without notice for improvement.

SPECIFICATIONS

Standard & Optional

Spindle		L3000Y/LY	L3000SY
Main Spindle Hollow Chuck 3 Jaw	12"	●	●
Main Spindle Solid Chuck 3 Jaw	12"	☆	☆
Sub Spindle Hollow Chuck 3 Jaw	6"	-	●
Sub Spindle Solid Chuck 3 Jaw	6"	-	☆
Standard Soft Jaw (1set)		●	●
Chuck Clamp Foot Switch		●	●
2 Steps Hyd. Pressure Device		○	○
Spindle Inside Stopper		☆	☆
5" Index		☆	☆
Cs-Axis (0.001")		●	●
2 Steps Chuck Foot Switch		○	○
Chuck Open/Close Confirmation Device		○ (CE:●)	○ (CE:●)
Sub Spindle Foot Switch		-	●
Turret			
Tool Holder		●	●
Mill Turret	BMT	●	●
Straight Milling Head (Radial)	Collet Type,2ea	●	●
Angular Milling Head (Axial)	Collet Type,2ea	●	●
Straight Milling Head (Radial)	Adapter Type	○	○
Angular Milling Head (Axial)	Adapter Type	○	○
Boring Sleeve		●	●
Drill Socket		●	●
U-Drill Holder		○	○
U-Drill Holder Sleeve		○	○
O.D Extension Holder	For Out-Dia	☆	☆
Angle Head		☆	☆
Tail Stock & Steady Rest			
Manual + Quill Tail Stock		●	-
Programmable + Quill Tail Stock(MT#5)		○	-
Programmable + Built-in Tail Stock(MT#4)		○	-
NC Feed + Quill Tail Stock(MT#5)		○	-
NC Feed + Built-in Tail Stock(MT#4)		○	-
Manual Hyd. Steady Rest (SMW/Khan/Shinkang/Samchully)		☆	☆
Programmable Hyd. Steady Rest		○ / ☆	☆
Standard Live Center		●	-
High Precision Live Center		○	-
2 Steps Tail Stock Pressure System		☆	-
Tail Stock Foot Switch (When Tail Stock is selected)		●	-
Quill Forward/Reverse Confirmation Device		○	-
Coolant & Air Blow			
Standard Coolant (Nozzle)		●	●
Chuck Coolant (Upper Chuck)		○	○
Gun Coolant		○	○
Through Spindle Coolant (Only for Special Chuck)		☆	☆
Turnmill Through Coolant		-	-
Chuck Air Blow (Upper Chuck)		○	○
Sub Spindle Air Blow		-	○
Tail Stock Air Blow (Upper Tail Stock)		☆	-
Turret Air Blow		☆	☆
Air Gun		○	○
Through Spindle Air Blow (Only for Special Chuck)		☆	☆
High Pressure Coolant	1.5Bar (21.8psi)	●	●
	6Bar (87psi)	○	○
	20Bar (290psi)	○	○
	70Bar (1,015psi)	○	○
Power Coolant System (For Automation)		☆	☆
Coolant Chiller (When selecting Sub Tank Type, Chip Conveyor)		☆	☆
집처리			
Coolant Tank	290 ℓ (76.6 gal)	● / -	●
	320 ℓ (84.5 gal)	- / ●	-
Chip Conveyor (Hinge/Scraper)	Front (Right)	○	○
	Rear (Rear)	○	○
Special Chip Conveyor (Drum Filter)		☆	☆

● : Standard ○ : Option ☆ : Prior Consultation - : Non Applicable

Chip Disposal		L3000Y/LY	L3000SY
Chip Wagon	Standard (180 ℓ [47.5 gal])	○	○
	Swing (200 ℓ [52.8 gal])	○	○
	Large Swing (290 ℓ [76.6 gal])	○	○
	Large Size (330 ℓ [87.2 gal])	○	○
	Customized	☆	☆
Safety Device			
Total Splash Guard		●	●
Chuck hydraulic pressure maintenance interlock		○ (CE:●)	○ (CE:●)
Electric Device			
Call Light	1Color : ●	●	●
Call Light	2Color : ● ●	○	○
Call Light	3Color : ● ● ●	○	○
Call Light & Buzzer	3Color : ● ● ● B	○	○
Electric Cabinet Light		○	○
Remote MPG		-	-
Work Counter	Digital	○	○
Total Counter	Digital	○	○
Tool Counter	Digital	○	○
Multi Tool Counter	Digital	○	○
Electric Circuit Breaker		○	○
AVR (Auto Voltage Regulator)		☆	☆
Transformer	50kVA	○	-
	65kVA	-	○
Auto Power Off		○	○
Measurement			
Manual Q-Setter		-	-
Automatic Q-Setter		●	●
Work Close Confirmation Device (TACO (Only for Special Chuck))	SMC	○	○
Work Setter		☆	☆
Linear Scale	X axis	☆	☆
	Z axis	☆	☆
Coolant Level Sensor (Only for Chip Conveyor)		☆	☆
Environment			
Air Conditioner		○	○
Oil Mist Collector		☆	☆
Oil Skimmer (Only for Chip Conveyor)		○	○
MLQ (Minimal Quantity Lubrication)		☆	☆
Fixture & Automation			
Auto Door	High Speed	○	○
Auto Shutter (Only for Automatic System)		☆	☆
Sub Operation Pannel		☆	☆
Bar Feeder Interface		○	○
Bar Feeder (FEDEK)		☆	☆
Sub Sp. Work Eject (Pneumatic Type)		-	○
Sub Sp. Work Pusher (Spring Type)		-	○
Turret Work Pusher (For Automation)		☆	☆
Extra M-Code 4ea		○	○
Automation Interface		☆	☆
I/O Extension (IN & OUT)	16 Contact	○	○
	32 Contact	○	○
Parts Catcher	Main SP.	○	○
	Sub SP.	-	○
Parts Conveyor(Need to Main Part Catcher)		☆	☆
Front Loading Semi Automation		☆	☆
Hyd. Device			
Standard Hyd. Cylinder	Hollow	●	●
Standard Hyd. Unit	35bar(507.6psi) / 14 ℓ (3.7gal)	●	●
S/W			
Machine Guidance (HW-MCG)		☆	☆
Energy Saving System (HW-ESS)		●	●
Tool Monitoring (HW-TM)		○	○
DNC software (HW-eDNC)		○	○
Machine Monitoring System (HW-MMS)		☆	☆
Conversational program (HW-DPRO)		-	-
ETC			
Tool Box		●	●
Customized Color	Need Munsel No.	☆	☆
CAD & CAM		☆	☆

SPECIFICATIONS

External Dimensions

unit : mm(in)

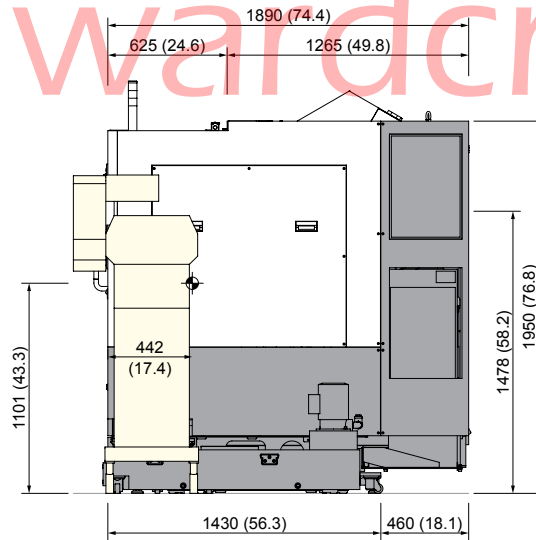
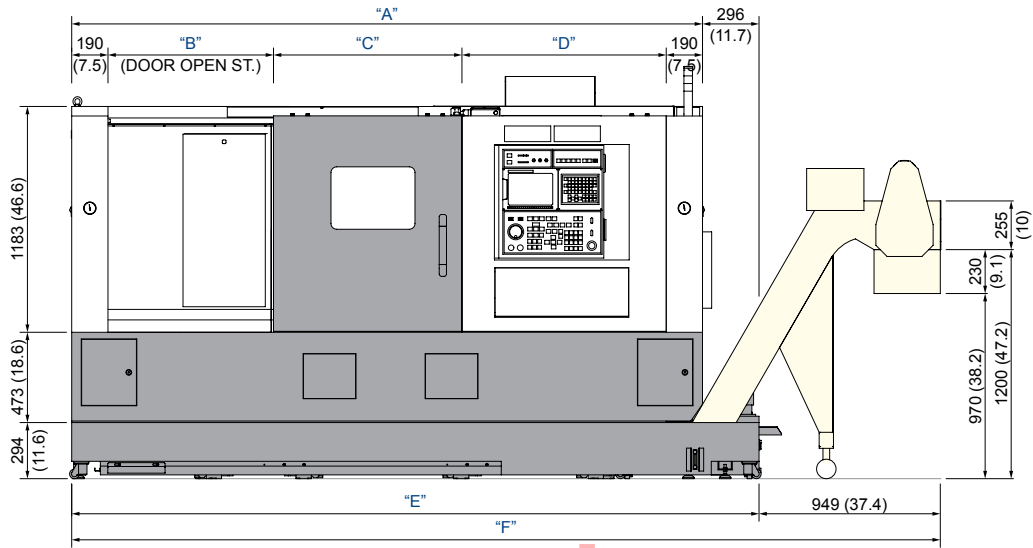

ITEM	L2000SY/L2000Y	L2000LSY / L2000LY / L2600SY L2600Y / L3000SY / L3000Y	L2600LY / L3000LY (2 DOOR TYPE)
"A"	2,974 (117.1")	3,304 (130.1")	4,074 (160.4")
"B"	690 (27.2")	860 (33.9")	841 (33.1")-Left / 651 (25.6")-Right
"C"	847 (33.3")	987 (38.9")	987 (38.9")
"D"	1,030 (40.6")	1,070 (42.1")	663 (26.1")
"E"	3,280 (129.1")	3,600 (141.7")	4,315 (169.9")
"F"	4,229 (166.5")	4,549 (179.1")	5,315 (209.3")

SPECIFICATIONS

Tooling System

unit : mm(in)

L2000Y/L2000LY/L2000SY/L2000LSY
L2600Y/L2600LY/L2600SY
L3000Y/L3000LY/L3000SY

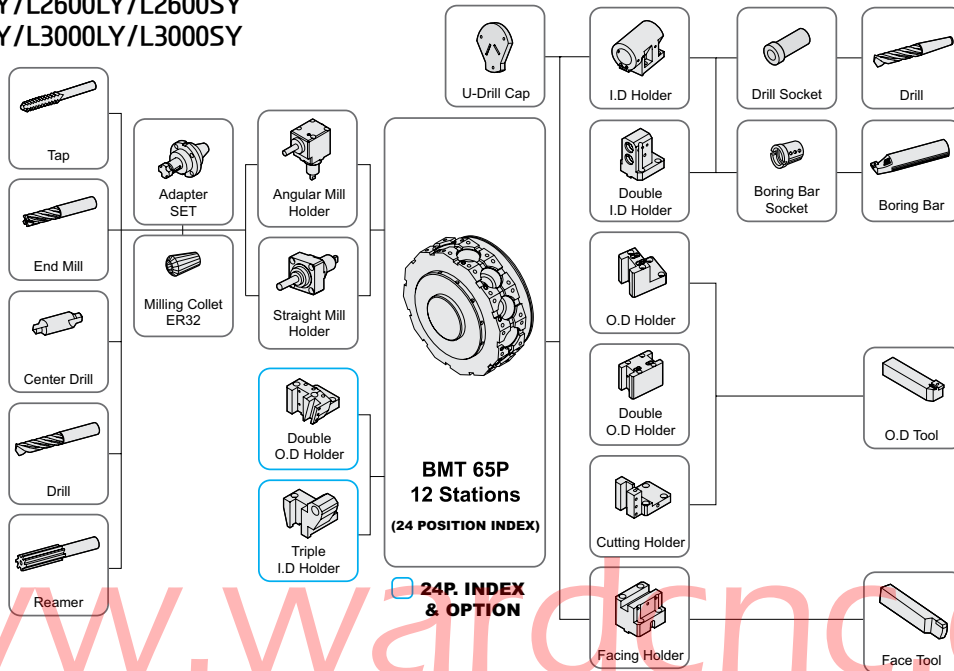

Tooling Parts Detail

ITEM			Y Type (12P)		SY Type (12P)		SY Type (24P : Opt.)	
			mm Unit	inch Unit	mm Unit	inch Unit	mm Unit	inch Unit
Turning Holder	O.D Holder	Right/Left	4	4	2	2	1	1
		Double	-	-	1	1	1	1
		Double (24P, Rear)	-	-	-	-	1	1
		Double (24P)	-	-	-	-	1	1
	Facing Holder		1	1	1	1	1	1
	Cutting Holder		-	-	1	1	1	1
Boring Holder	I.D Holder	Single	3	3	2	2	1	1
		Double	-	-	1	1	-	-
		Triple	-	-	-	-	1	1
	U-Drill Holder	Cap	1	1	1	1	1	1
Driven Holder	Straight Mill Holder	Standard	2	2	2	2	2	2
	Angular Mill Holder	Standard	2	2	2	2	2	2
Socket	Boring	Ø16 (Ø5/8")	1	-	1	-	1	-
		Ø20 (Ø3/4")	1	1	1	1	1	1
		Ø25 (Ø1")	1	1	1	1	1	1
		Ø32 (Ø1 1/4")	1	1	1	1	1	1
		Ø40 (Ø1 1/2")	1	1	1	1	1	1
		Ø45 (Ø1 3/4")	-	1	-	1	-	1
	Sub Boring	Ø10 (Ø3/8")	-	-	1	1	1	1
		Ø12 (Ø1/2")	-	-	1	1	1	1
		Ø16 (Ø5/8")	-	-	1	1	1	1
		Ø20 (Ø3/4")	-	-	1	1	1	1
	Drill	MT 2	1	1	1	1	1	1
		MT 3	1	1	1	1	1	1
		MT 4	1	1	1	1	1	1
		ER Collet		1 Set	1 Set	1 Set	1 Set	1 Set
		Adapter Set		1 Set	1 Set	1 Set	1 Set	1 Set

SPECIFICATIONS

Interference

unit : mm(in)

Y Series

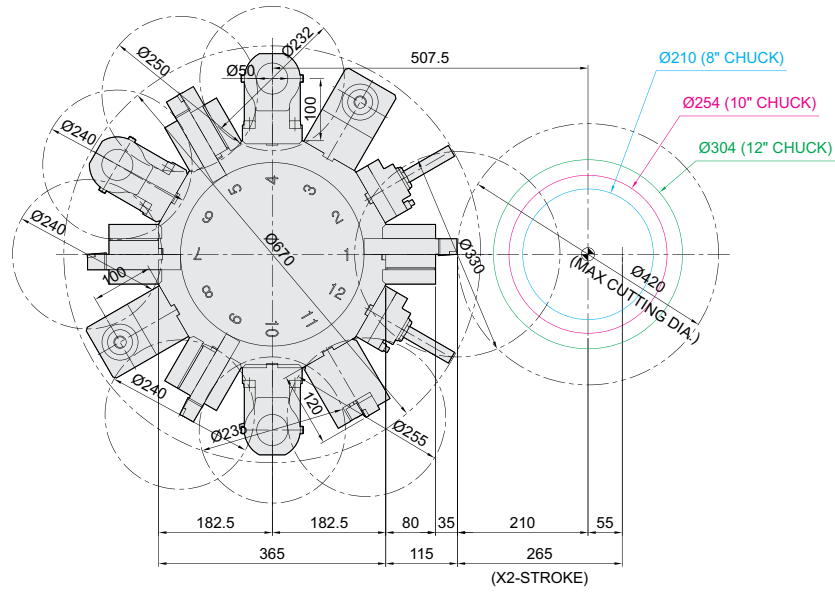

SY Series

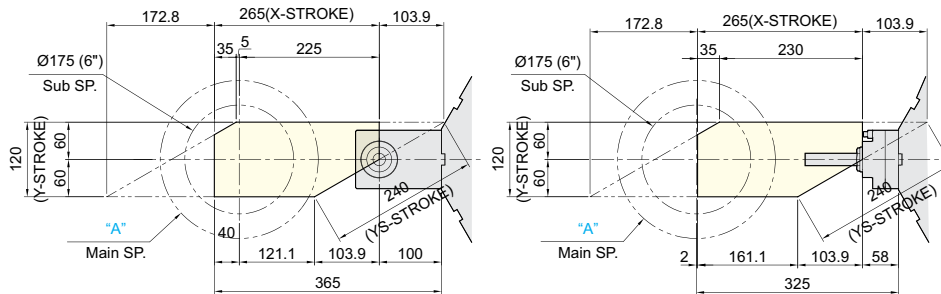
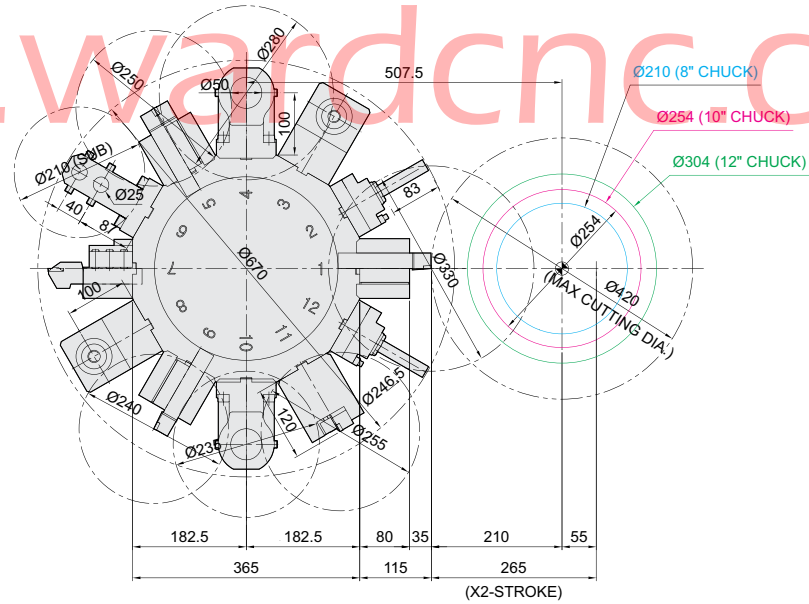

"A" : L2000 Series (8") | L2600 Series (10") | L3000 Series (12")

SPECIFICATIONS

Tooling Travel Range

unit : mm(in)

L2000Y

O.D. Tool holder

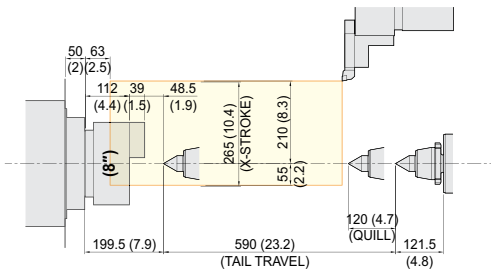

I.D. Tool holder

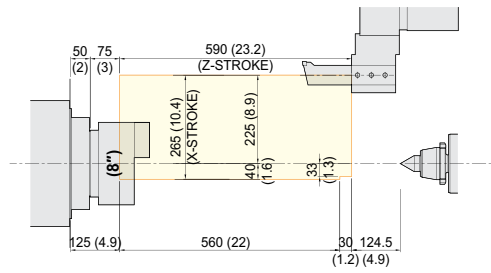

Axial driven Tool holder

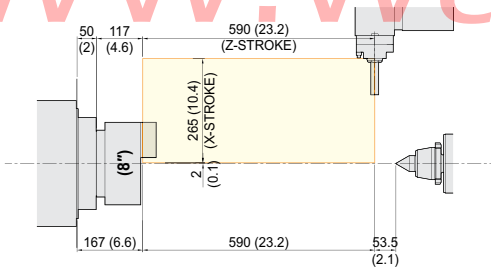

Angular driven Tool holder

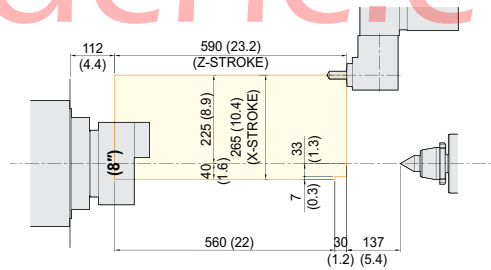

Face Tool holder

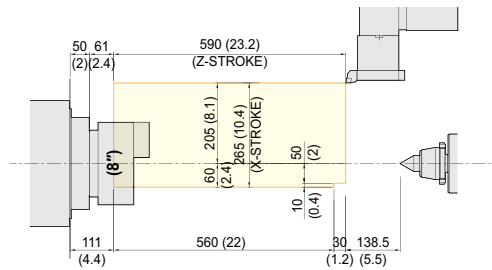

www.wardenc.com

SPECIFICATIONS

Tooling Travel Range

unit : mm(in)

L2000LY

O.D. Tool holder

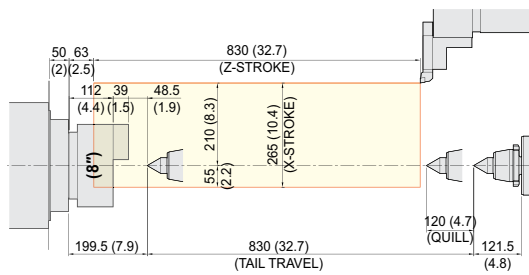

I.D. Tool holder

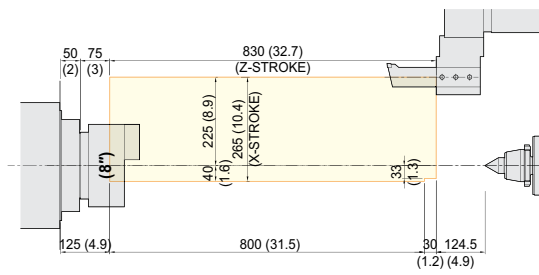

Axial driven Tool holder

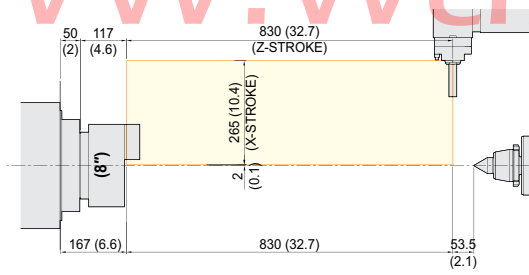

Angular driven Tool holder

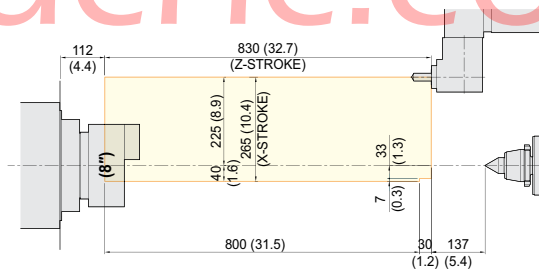

Face Tool holder

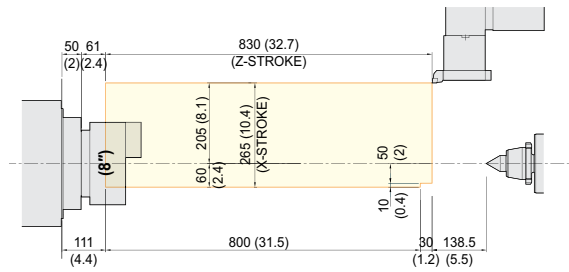

www.wardcnc.com

SPECIFICATIONS

Tooling Travel Range

unit : mm(in)

L2000SY

O.D. Tool holder

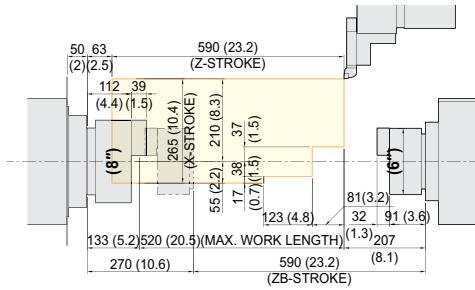

I.D. Tool holder

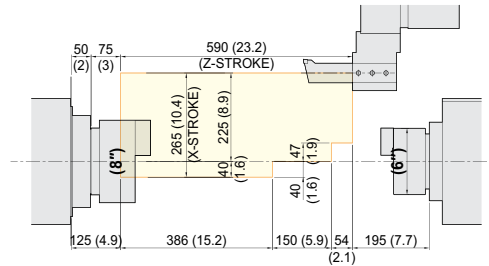

Double O.D. Tool holder

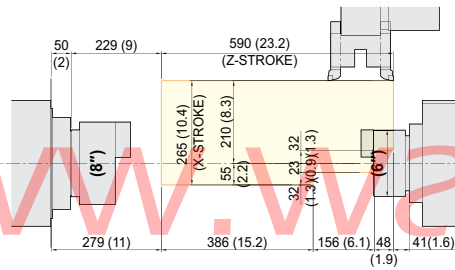

Double I.D. Tool holder

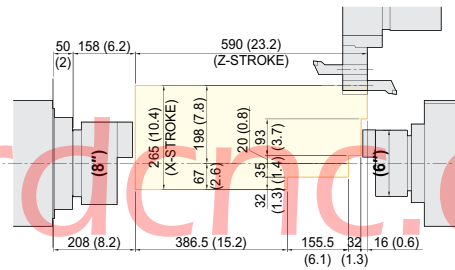

Axial driven Tool holder

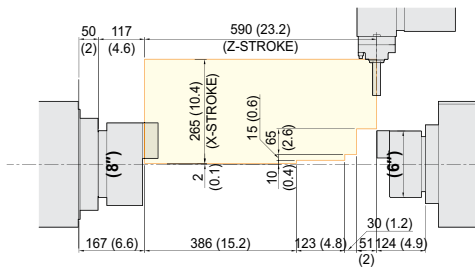

Angular driven Tool holder

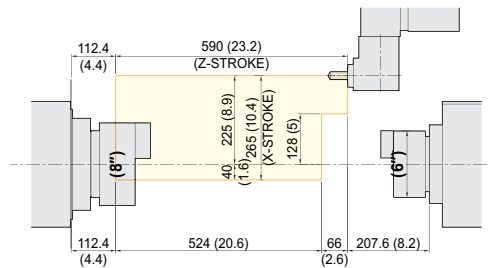

Face Tool holder

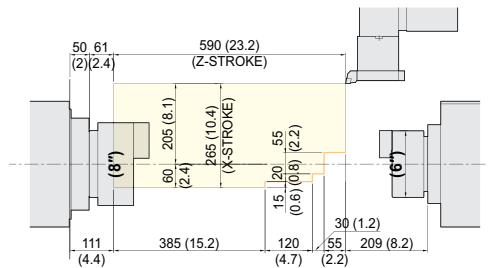

www.vward.com

SPECIFICATIONS

Tooling Travel Range

unit : mm(in)

L2000LSY

O.D. Tool holder

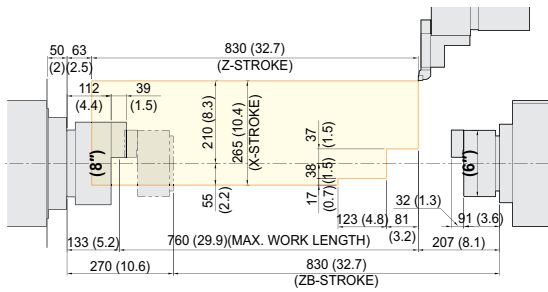

I.D. Tool holder

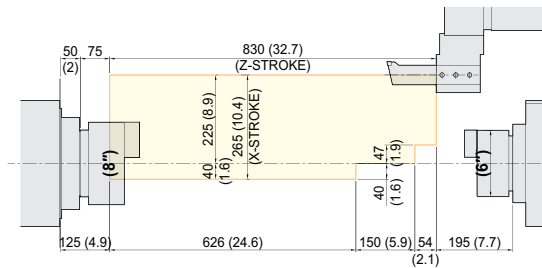

Double O.D. Tool holder

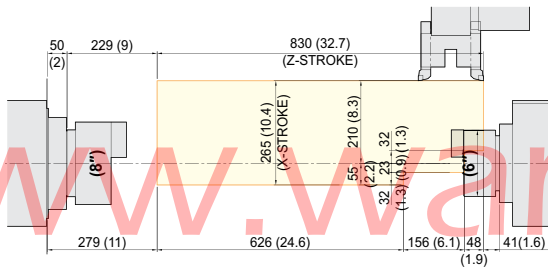

Double I.D. Tool holder

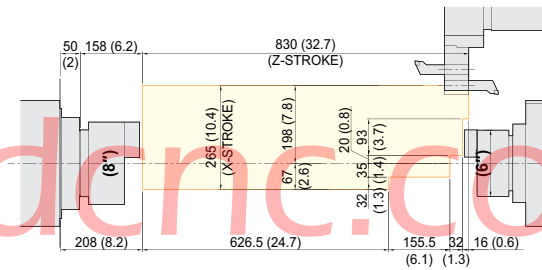

Axial driven Tool holder

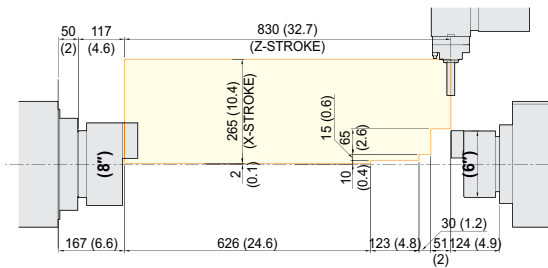

Angular driven Tool holder

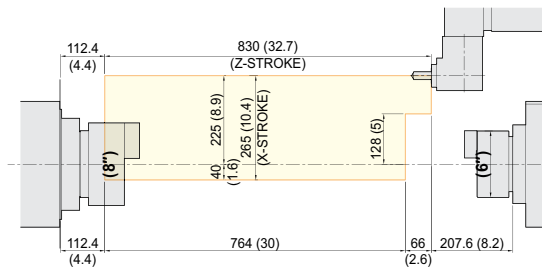

Face Tool holder

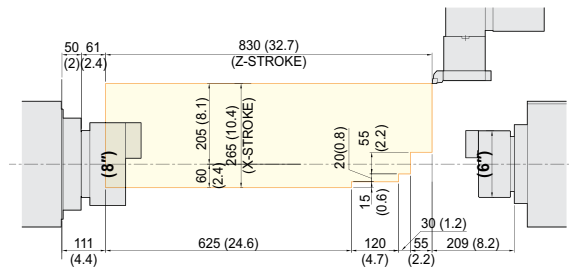

SPECIFICATIONS

Tooling Travel Range

unit : mm(in)

L2600Y

O.D. Tool holder

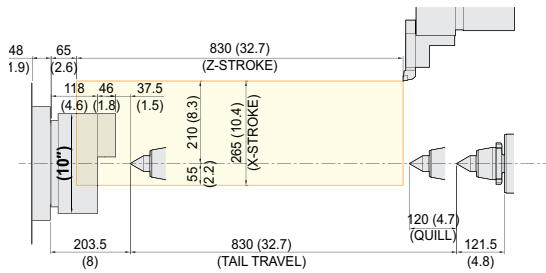

I.D. Tool holder

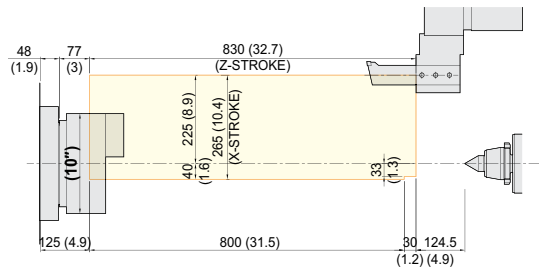

Axial driven Tool holder

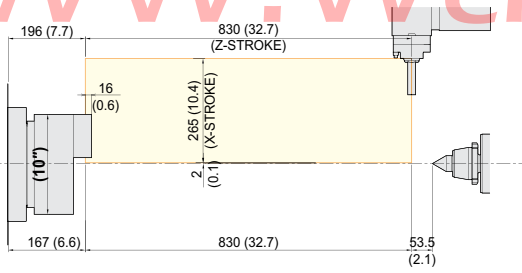

Angular driven Tool holder

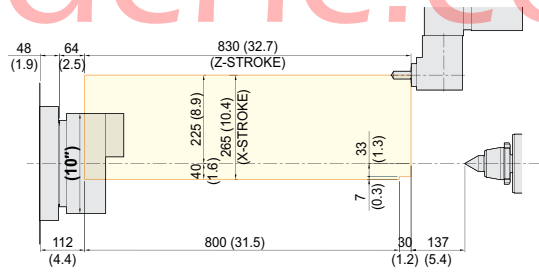

Face Tool holder

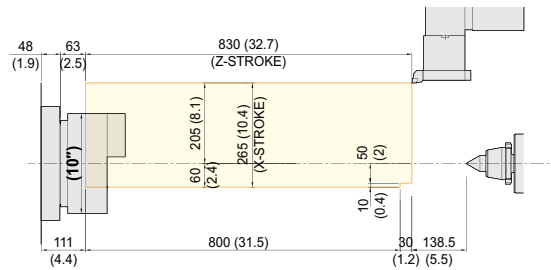

www.wardcnc.com

SPECIFICATIONS

Tooling Travel Range

unit : mm(in)

L2600SY

O.D. Tool holder

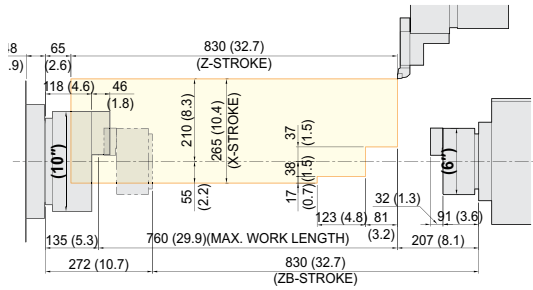

I.D. Tool holder

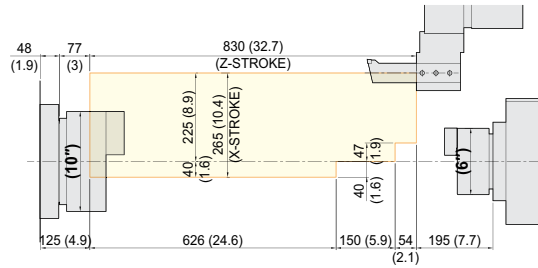

Double O.D. Tool holder

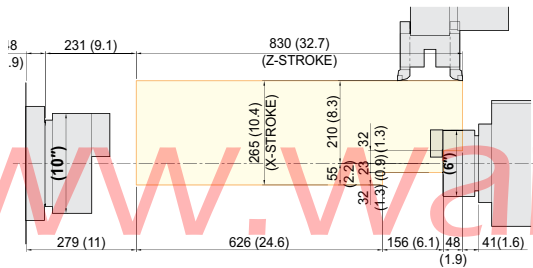

Double I.D. Tool holder

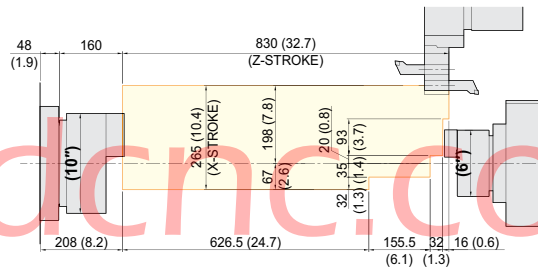

Axial driven Tool holder

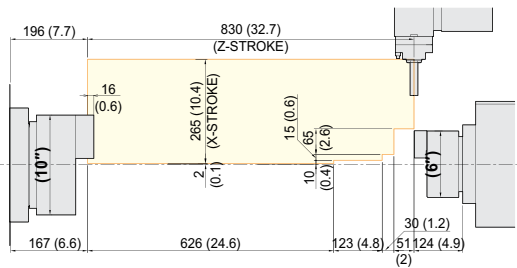

Angular driven Tool holder

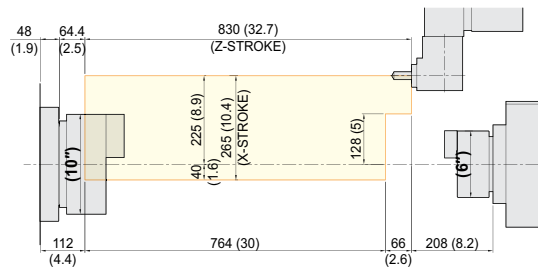

Face Tool holder

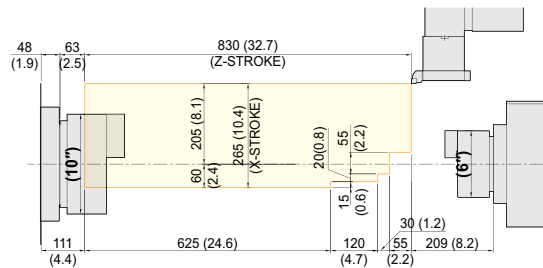

SPECIFICATIONS

Tooling Travel Range

unit : mm(in)

L2600LY

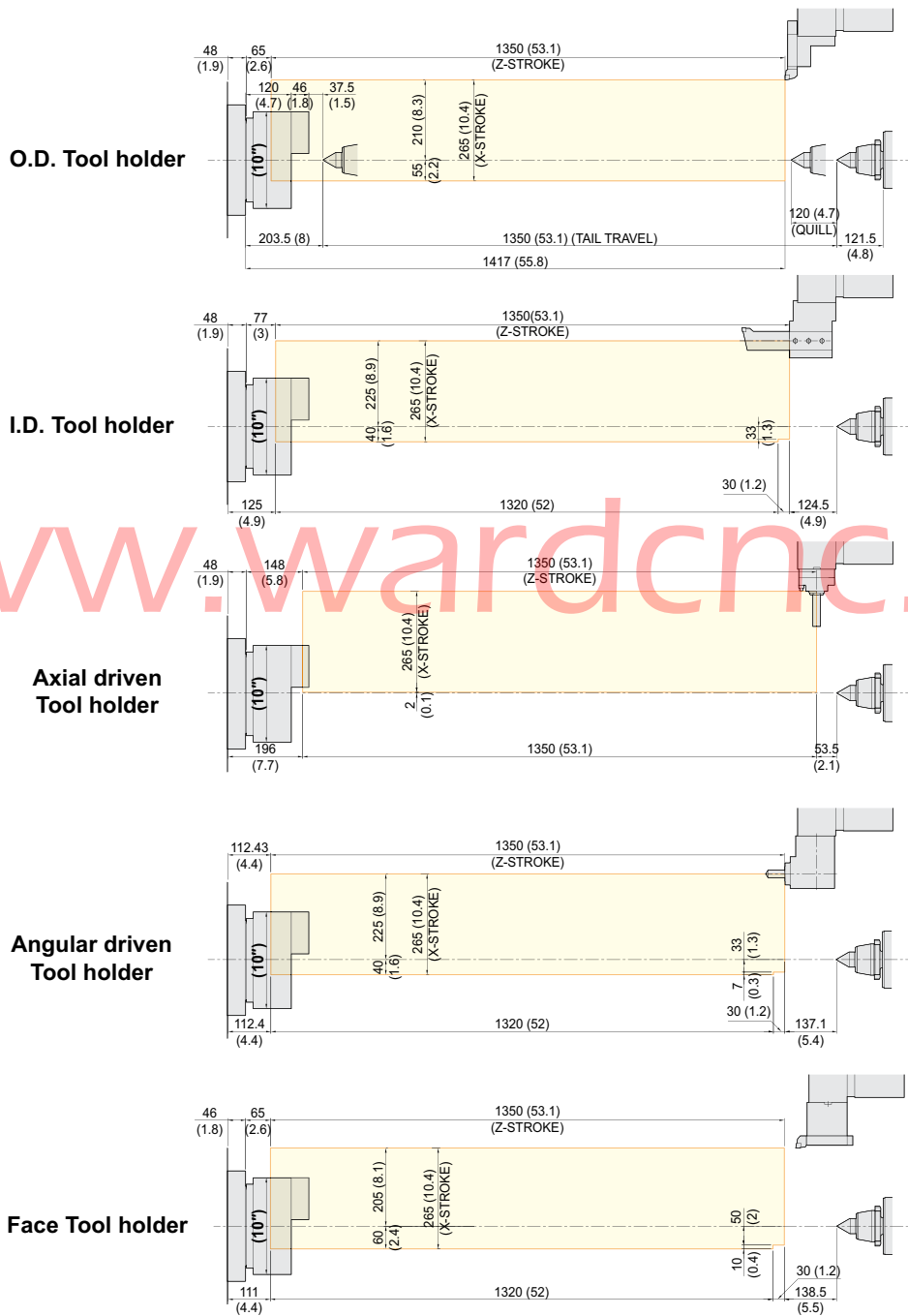

www.wardcnc.com

SPECIFICATIONS

Tooling Travel Range

unit : mm(in)

L3000Y

O.D. Tool holder

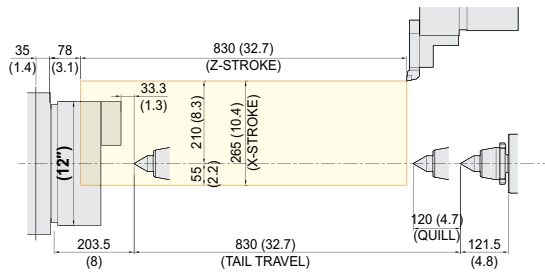

I.D. Tool holder

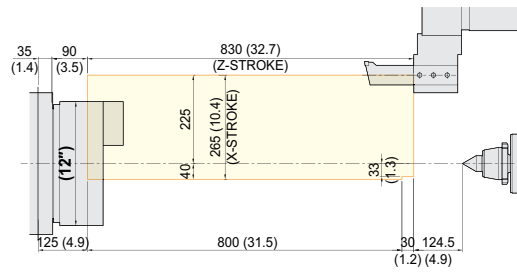

Axial driven Tool holder

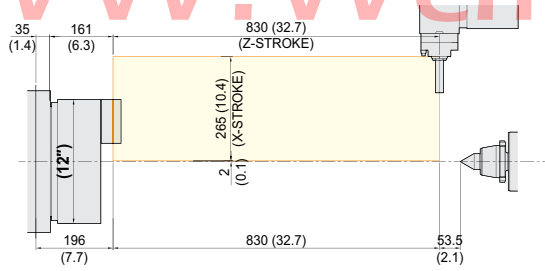

Angular driven Tool holder

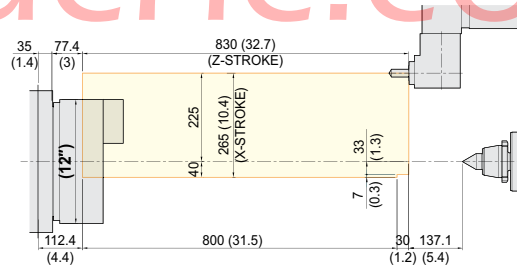

Face Tool holder

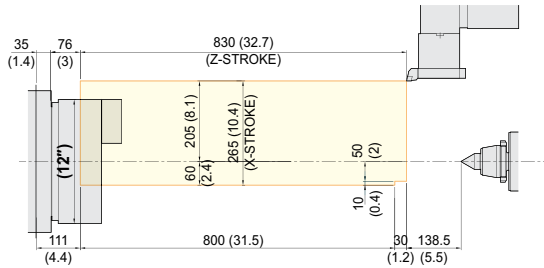

www.wardcnc.com

SPECIFICATIONS

Tooling Travel Range

unit : mm(in)

L3000SY

O.D. Tool holder

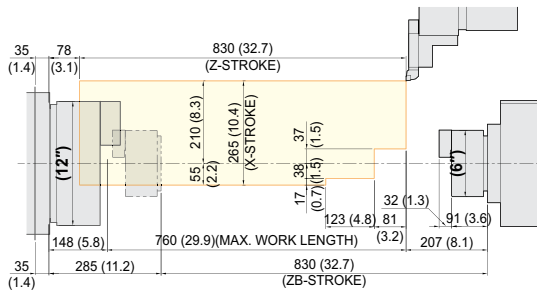

I.D. Tool holder

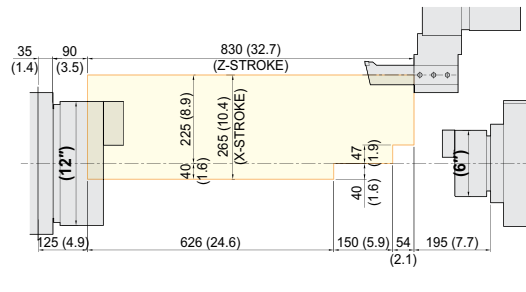

Double O.D. Tool holder

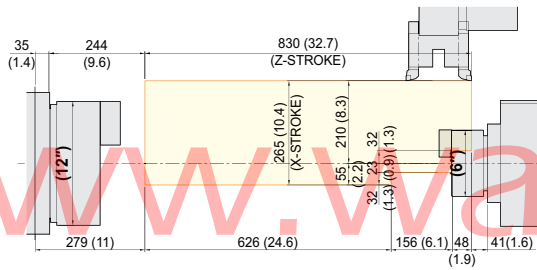

Double I.D. Tool holder

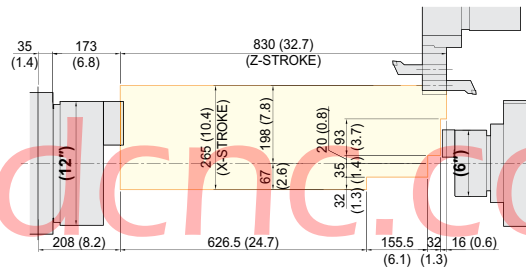

Axial driven Tool holder

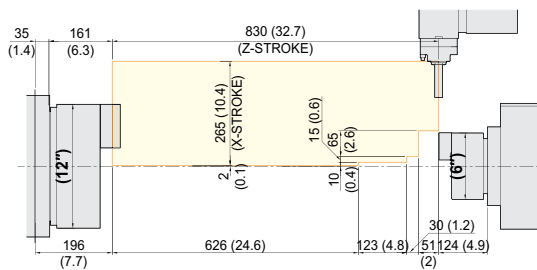

Angular driven Tool holder

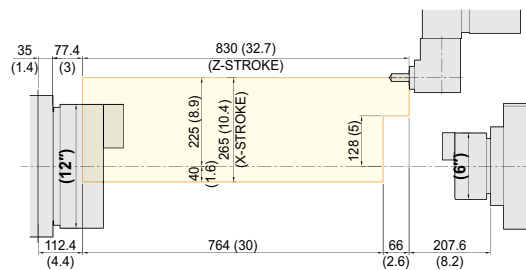

Face Tool holder

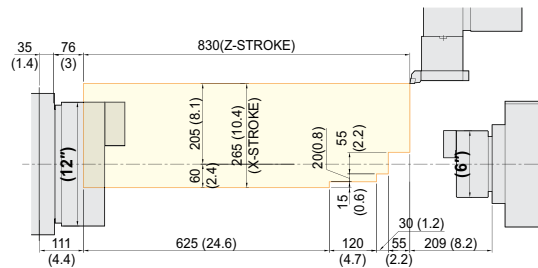

www.vwardcnc.com

SPECIFICATIONS

Tooling Travel Range

unit : mm(in)

L3000LY

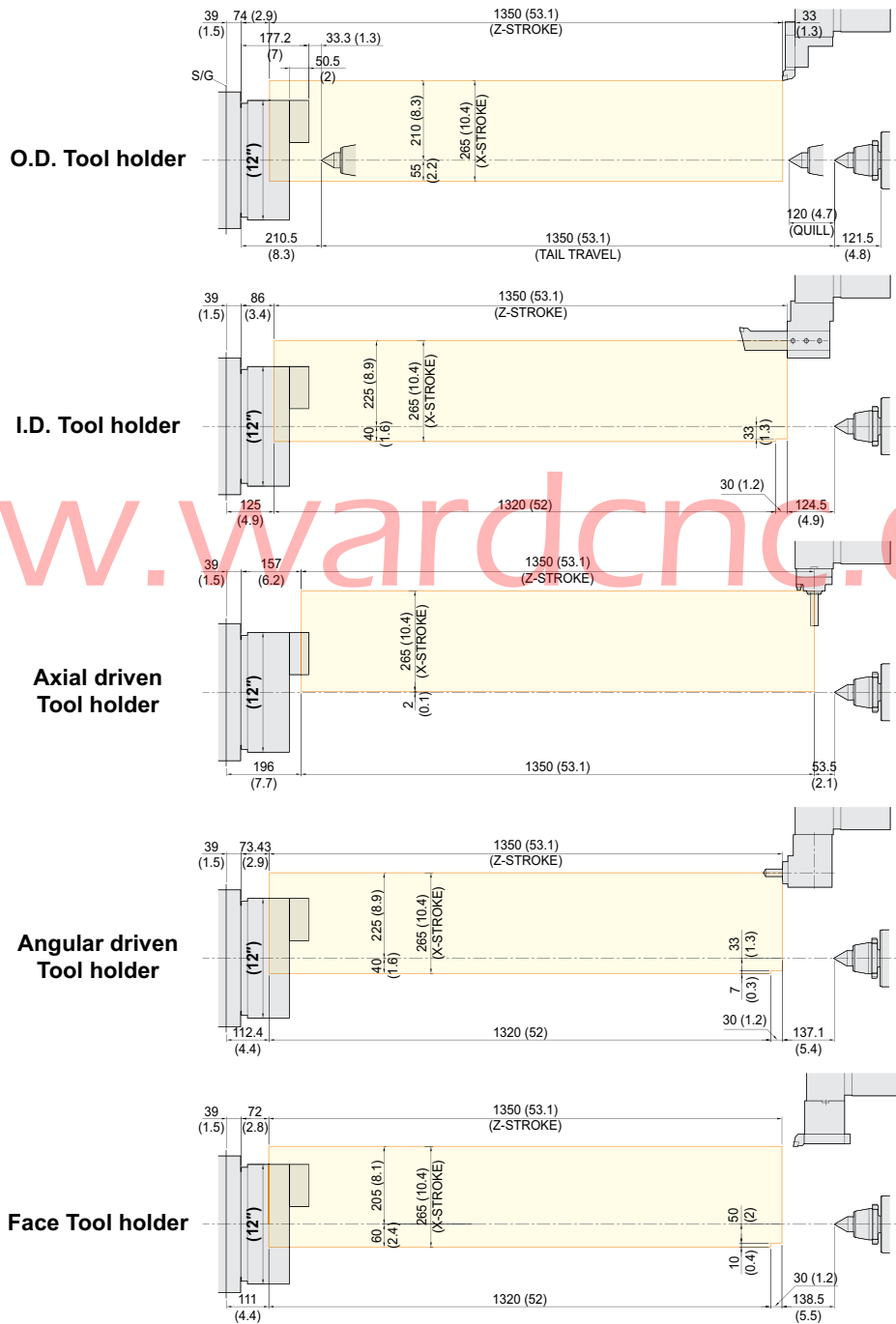

www.wardcnc.com

SPECIFICATIONS

Specifications

[] : Option

ITEM			L2000Y	L2000LY	L2000SY	L2000LSY
CAPACITY	Swing Over the Bed	mm(in)	Ø870 (34.3")			
	Swing Over the Carriage	mm(in)	Ø670 (26.4")			
	Max. Turning Dia.	mm(in)	Ø420 (16.5")			
	Max. Turning Length	mm(in)	520 (20.5")	760 (29.9")	520 (20.5")	760 (29.9")
	Bar Capacity	Main	mm(in)	Ø65 (2.6")		
Sub		mm(in)	-			
SPINDLE	Chuck Size	Main	8"			
		Sub	-			
	Spindle Bore	Main	Ø76 (3")			
		Sub	-			
	Spindle Speed (rpm)	Main	5,000 [4,500]			
		Sub	-			
	Motor (Max/Cont.)	Main	22/11 (29.5/14.8) [18.5/11 (24.8/14.8)]			
		Sub	-			
	Torque (Max/Cont.)	Main	358/301 (264/222) [314.2/186.2 (231.7/137.3)]			
		Sub	-			
	Spindle Type	Main	Built-in [Belt]			
		Sub	-			
	Spindle Nose	Main	A2-6			
Sub		-				
C-axis Indexing	deg	0.001°				
FEED	Travel	X/Y	265/120 {±60} (10.4"/4.7" {±2.4"})			
		Z/ZB	590 (23.2")	830 (32.7")	590/590 (23.2"/23.2")	830/830 (32.7"/32.7")
	Rapid Traverse Rate	X/Y	30/10 (1,181/394)			
		Z/ZB	30/30 (1,181/1,181)			
Slide Type	-	BOX GUIDE				
TURRET	No. of Tools	ea	12			
	Tool Size	OD	□25 (1")			
		ID	Ø50 (2")			
	Indexing Time	sec/step	0.15			
Y-Axis Type	-	WEDGE TYPE				
LIVE TOOL	Motor (Max/Cont.)	kw(HP)	5.5/1.5 (7.4/2)			
	Milling Tool Speed (rpm)	r/min	5,000			
	Torque (Max/Cont.)	N·m(lbf·ft)	47.1/33.7 (34.7/24.9)			
	Collet Size	mm(in)	Ø25 (1") {ER32}			
	Type	-	BMT65P			
TAIL STOCK	Taper	-	MT#5		-	
	Quill Dia.	mm(in)	Ø100 (3.9")			
	Quill Travel	mm(in)	120 (4.7")			
	Travel	mm(in)	590 (23.2")	830 (32.7")	-	
TANK CAPACITY	Coolant Tank	ℓ (gal)	275 (72.6)	290 (76.6)	275 (72.6)	290 (76.6)
	Lubricating Tank	ℓ (gal)	3 (0.8)			
POWER SUPPLY	Electric Power Supply	kVA	31		45	
	Thickness of Power Cable	Sq	Over 25		Over 35	
	Voltage	V/Hz	220/60 (200/50*)			
MACHINE	Floor Space (L×W)	mm(in)	3,220×1,890 (126.8"×74.4")	3,600×1,890 (141.7"×74.4")	3,220×1,890 (126.8"×74.4")	3,600×1,890 (141.7"×74.4")
	Height	mm(in)	1,950 (76.8)			
	Weight	kg(lb)	5,500 (12,125)	6,000 (13,228)	5,800 (12,787)	6,300 (13,889)
NC	Controller	-	HW FANUC i Series			

*) Using 50Hz voltage instead of 60Hz may lower the output of motors. (excluding servo motors and inverter motors)

Specifications are subject to change without notice for improvement.

SPECIFICATIONS

Specifications

[] : Option

ITEM			L2600Y	L2600LY	L2600SY	
CAPACITY	Swing Over the Bed	mm(in)		Ø870 (34.3")		
	Swing Over the Carriage	mm(in)		Ø670 (26.4")		
	Max. Turning Dia.	mm(in)		Ø420 (16.5")		
	Max. Turning Length	mm(in)	760 (29.9")	1,280 (50.4")	760 (29.9")	
	Bar Capacity	Main	mm(in)		Ø81 (3.2")	
Sub		mm(in)		-	Ø51 (2")	
SPINDLE	Chuck Size	Main	inch	10"		
		Sub	inch	-	6"	
	Spindle Bore	Main	mm(in)		Ø91 (3.6")	
		Sub	mm(in)		-	Ø62 (2.4")
	Spindle Speed (rpm)	Main	r/min	4,000 [3,500]		
		Sub	r/min		-	6,000 [4,500]
	Motor (Max/Cont.)	Main	kW(HP)	22/15 (29.5/20.1) [26/18.5 (34.9/24.8)]		
		Sub	kW(HP)		-	15/11 (20.1/14.8) [11/5.5 (14.8/4)]
	Torque (Max/Cont.)	Main	N·m(lbf·ft)	599/409 (441.8/301.7) [733.7/522.1 (541.1/385.1)]		
		Sub	N·m(lbf·ft)		-	135/99.1 (99.6/73.1) [124/62.1 (91.5/45.8)]
	Spindle Type	Main	-	Built-in [Belt]		
Sub		-		-	Built-in [Belt]	
Spindle Nose	Main	-	A2-8			
	Sub	-		-	A2-5	
C-axis Indexing		deg	0.001°			
FEED	Travel	X/Y	mm(in)	265/120 {±60} (10.4"/4.7" {±2.4"})		
		Z/ZB	mm(in)	830 (32.7")	1,350 (53.1)	830/830 (32.7"/32.7")
	Rapid Traverse Rate	X/Y	m/min(ipm)	30/10 (1,181/394)		
		Z/ZB	m/min(ipm)	30/30 (1,181/1,181)		
Slide Type		-	BOX GUIDE			
TURRET	No. of Tools		ea	12		
	Tool Size	OD	mm(in)	□ 25 (1")		
		ID	mm(in)	Ø50 (2")		
	Indexing Time		sec/step	0.15		
Y-Axis Type		-	WEDGE TYPE			
LIVE TOOL	Motor (Max/Cont.)		kW(HP)	5.5/1.5 (7.4/2)		
	Milling Tool Speed (rpm)		r/min	5,000		
	Torque (Max/Cont.)		N·m(lbf·ft)	47.1/33.7 (34.7/24.9)		
	Collet Size		mm(in)	Ø25 (1") [ER32]		
	Type		-	BMT65P		
TAIL STOCK	Taper		-	MT#5	-	
	Quill Dia.		mm(in)	Ø100 (3.9")	-	
	Quill Travel		mm(in)	120 (4.7")	-	
	Travel		mm(in)	830 (32.7")	1,350 (53.1)	-
TANK CAPACITY	Coolant Tank		ℓ (gal)	290 (76.6)	320 (84.5)	290 (76.6)
	Lubricating Tank		ℓ (gal)	3 (0.8)		
POWER SUPPLY	Electric Power Supply		kVA	31	45	
	Thickness of Power Cable		Sq	Over 25	Over 35	
	Voltage		V/Hz	220/60 (200/50*)		
MACHINE	Floor Space (L×W)		mm(in)	3,600×1,890 (141.7"×74.4")	4,120×1,890 (162.2"×74.4")	3,600×1,890 (141.7"×74.4")
	Height		mm(in)	1,950 (76.8)		
	Weight		kg(lb)	6,200 (13,669)	7,500 (16,535)	6,550 (14,440)
PC	Controller		-	HW FANUC i Series		

*] Using 50Hz voltage instead of 60Hz may lower the output of motors. (excluding servo motors and inverter motors)
Specifications are subject to change without notice for improvement.

SPECIFICATIONS

Specifications

[] : Option

ITEM			L3000Y	L3000LY	L3000SY
CAPACITY	Swing Over the Bed	mm(in)	Ø870 (34.3")		
	Swing Over the Carriage	mm(in)	Ø670 (26.4")		
	Max. Turning Dia.	mm(in)	Ø420 (16.5")		
	Max. Turning Length	mm(in)	760 (29.9")	1,280 (50.4")	760 (29.9")
	Bar Capacity	Main	mm(in)	Ø102 (4")	
Sub		mm(in)	-	-	Ø51 (2")
SPINDLE	Chuck Size	Main	12"		
		Sub	-	-	6"
	Spindle Bore	Main	Ø115 (4.5")		
		Sub	-	-	Ø62 (2.4")
	Spindle Speed (rpm)	Main	3,000 [2,800]		
		Sub	-	-	6,000 [4,500]
	Motor (Max/Cont.)	Main	37/25 (49.6/33.5) [26/18.5 (34.9/24.8)]		
		Sub	-	-	15/11 (20.1/14.8) [11/5.5 (14.8/7.4)]
	Torque (Max/Cont.)	Main	1,262/1,003 (930.8/739.8) [1,123/664 (828.2/489.7)]		
		Sub	-	-	135/99.1 (99.6/73.1) [124/62.1 (91.5/45.8)]
Spindle Type	Main	-	Built-in [Belt]		
	Sub	-	-	Built-in [Belt]	
Spindle Nose	Main	-	A2-11		
	Sub	-	-	A2-5	
C-axis Indexing		deg	0.001°		
FEED	Travel	X/Y	265/120 {±60} (10.4"/4.7" {±2.4"})		
		Z/ZB	830 (32.7")	1,350 (53.1)	830/830 (32.7"/32.7")
	Rapid Traverse Rate	X/Y	30/10 (1,181/394)		
		Z/ZB	30/30 (1,181/1,181)		
Slide Type	-	BOX GUIDE			
TURRET	No. of Tools	ea	12		
	Tool Size	OD	□25 (1")		
		ID	Ø50 (2")		
	Indexing Time	sec/step	0.15		
Y-Axis Type	-	WEDGE TYPE			
LIVE TOOL	Motor (Max/Cont.)	kw(HP)	5.5/1.5 (7.4/2)		
	Milling Tool Speed (rpm)	r/min	5,000		
	Torque (Max/Cont.)	N·m(lbf·ft)	47.1/33.7 (34.7/24.9)		
	Collet Size	mm(in)	Ø25 (1") {ER32}		
	Type	-	BMT65P		
TAIL STOCK	Taper	-	MT#5		-
	Quill Dia.	mm(in)	Ø100 (3.9")		-
	Quill Travel	mm(in)	120 (4.7")		-
	Travel	mm(in)	830 (32.7")	1,350 (53.1)	-
TANK CAPACITY	Coolant Tank	ℓ (gal)	290 (76.6)	320 (84.5)	290 (76.6)
	Lubricating Tank	ℓ (gal)	3 (0.8)		
POWER SUPPLY	Electric Power Supply	kVA	43		57
	Thickness of Power Cable	Sq	Over 35		Over 50
	Voltage	V/Hz	220/60 (200/50*)		
MACHINE	Floor Space (L×W)	mm(in)	3,600×1,890 (141.7"×74.4")	4,320×1,890 (170.1"×74.4")	3,600×1,890 (141.7"×74.4")
	Height	mm(in)	1,950 (76.8")		
	Weight	kg(lb)	6,700 (14,771)	7,800 (17,196)	6,900 (15,212)
NC	Controller	-	HW FANUC i Series		

*) Using 50Hz voltage instead of 60Hz may lower the output of motors. (excluding servo motors and inverter motors)

Specifications are subject to change without notice for improvement.

CONTROLLER

HYUNDAI WIA FANUC i Series

[] : Option

Controlled axis / Display / Accuracy Compensation	
Control axes	2 axes (X, Z) / 3 axes (X, Z, C / X, Z, B) / 4 axes (X, Z, Y, C) 5 axes (X, Z, B, C, A) / 6 axes (X, Z, Y, B, C, A)
Simultaneously controlled axes	2 axes [Max. 4 axes]
Designation of spindle axes	3 axes (1 path)
Least setting Unit	X, Z, Y, B axes : 0.001 mm (0.0001 inch) C, A axes : 0.001 deg
Least input increment	X, Z, Y, B axes : 0.001 mm (0.0001 inch) C, A axes : 0.001 deg
Inch / Metric conversion	G20 / G21
High response vector control	
Interlock	All axes / Each axis
Machine lock	All axes
Backlash compensation	± 0 ~ 9999 pulses (Rapid traverse / Cutting feed)
Position switch	
LCD / MDI	8.4 inch / 10.4 inch color LCD
Feedback	Absolute motor feedback
Stored stroke check 1	Over travel
Stored stroke check 2, 3	
PMC axis control	
Operation	
Automatic operation (Memory)	
MDI operation	
DNC operation	Needed DNC software / CF card
Program restart	
Wrong operation prevention	
Program check function	Dry run
Single block	
Search function	Program Number / Sequence Number
Interpolation functions	
Nano interpolation	
Positioning	G00
Linear interpolation	G01
Circular interpolation	G02, G03
Exact stop mode	Single : G09, Continuous : G61
Dwell	G04, 0 ~ 9999.9999 sec
Skip	G31
Reference position return	1st reference : G28 2nd reference : G30 Ref. position check : G27
Thread synchronous cutting	
Thread cutting retract	
Variable lead thread cutting	
Multi / Continuous threading	
Feed function / Acc. & Dec. control	
Manual feed	Rapid traverse Jog : 0~2,000 mm/min (79 ipm) Manual handle : x1, x10, x100 pulses Reference position return
Cutting Feed command	Direct input F code
Feedrate override	0 ~ 200% (10% Unit)
Rapid traverse override	F1%, F5%, F25% / 50%, F100%
Override cancel	
Feed per minute	G98
Feed per revolution	G99
Look-ahead block	1 block
Program input	
Tape Code	EIA / ISO
Optional block skip	1 ea
Absolute / Incremental program	G90 / G91
Program stop / end	M00, M01 / M02, M30
Maximum command unit	± 999,999.999 mm (± 99,999.9999 inch)
Plane selection	X-Y : G17 / Z-X : G18 / Y-Z : G19
Workpiece coordinate system	G52, G53, 6 pairs (G54 ~ G59)
Manual absolute	Fixed ON
Programmable data input	G10
Sub program call	10 folds nested
Custom macro	#100 ~ #149, #500 ~ #549
G code system	A
Programmable mirror image	G51.1, G50.1
G code preventing buffering	G4.1
Direct drawing dimension program	Including Chamfering / Corner R

Program input	
Multiple repetitive cycles	I, II
Canned cycle for turning	
Auxiliary function / Spindle speed function	
Auxiliary function	M & 4 digit
Level-up M Code	High speed / Multi / Bypass M code
Spindle speed function	S & 4 digit, Binary output
Spindle override	0% ~ 150% (10% Unit)
Multi position spindle orientation	M19
Rigid tapping	
Constant surface speed control	G96, G97
Tool function / Tool compensation	
Tool function	T & 2 digit + Offset 2 digit
Tool life management	
Tool offset pairs	128 pairs
Tool nose radius compensation	G40, G41, G42
Geometry / Wear compensation	
Direct input of offset measured B	
Editing function	
Part program storage size	1280m (512KB)
No. of registerable programs	1000 ea
Program protect	
Background editing	
Extended part program editing	Copy, move and change of NC program
Memory card program edit	
Data input / output & Interface	
I/O interface	RS 232C serial port, CF card, USB memory Embedded Ethernet interface
Screen hard copy	
External message	
External key input	
External workpiece number search	
Automatic data backup	
Setting, display and diagnosis	
Self-diagnosis function	
History display & Operation	Alarm & Operator message & Operation
Run hour / Parts count display	
Maintenance information	
Actual cutting feedrate display	
Display of spindle speed / T code	
Graphic display	
Operating monitor screen	Spindle / Servo load etc.
Power consumption monitoring	Spindle & Servo
Spindle / Servo setting screen	
Multi language display	Support 20 languages
Display language switching	Selection of 5 optional Languages
LCD Screen Saver	Screen saver
Unexpected disturbance torque	BST (Back spin torque limit)
Function for machine type	
Cs contour control (C & A axes)	Mill, MS, Y, SY, LF-Mill, TTMS, TTSY
Polar coordinate interpolation	Mill, MS, Y, SY, LF-Mill, TTMS, TTSY
Cylindrical interpolation	Mill, MS, Y, SY, LF-Mill, TTMS, TTSY
Canned cycle for drilling	Mill, MS, Y, SY, LF-Mill, TTMS, TTSY
Spindle orientation expansion	MS, SY TTS, TTMS, TTSY
Spindle synchronous control	MS, SY TTS, TTMS, TTSY
Torque control	MS, SY TTS, TTMS, TTSY
Y axis offset	Y, SY, TTSY
Arbitrary angular control	Y, SY, TTSY
Composite / Superimposed control	MS, SY TTS, TTMS, TTSY
Balance cutting	MS, SY TTS, TTMS, TTSY
Option	
Optional block skip	9 ea
Fast ethernet	Need board option
Data server	Need board option
Protection of data at 8 levels	
Tool offset pairs	200 pairs
Part program storage size	5120m (2MB)
Polygon turning (2 Spindles)	Mill, MS, Y, SY, LF-Mill, TTMS, TTSY
Helical interpolation	
Manual Guide i	Conversational auto program
Dynamic graphic display	

GLOBAL NETWORK



Hyundai WIA
Machine Tools America



Hyundai WIA
Machine Tools Europe
Raunheim Service Center
Raunheim R&D Center

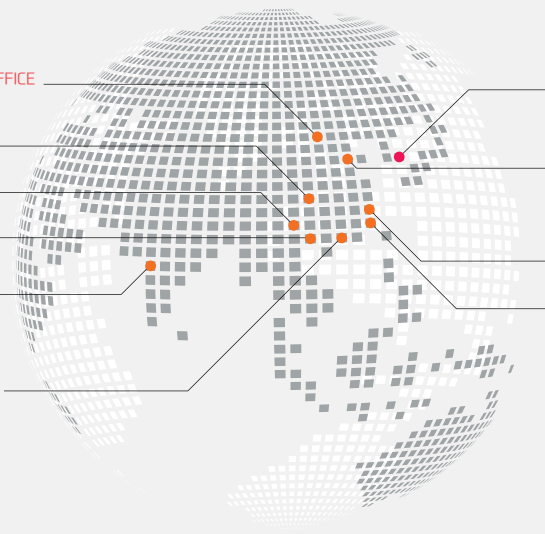

BEIJING BRANCH OFFICE
WUHAN OFFICE
CHENGDU BRANCH OFFICE
CHONGQING OFFICE
INDIA BRANCH OFFICE
GUANGZHOU BRANCH OFFICE
HEADQUARTER
QINGDAO BRANCH OFFICE
JIANGSU HYUNDAI WIA
Hyundai WIA
Machine Tools China
SHANGHAI BRANCH OFFICE

www.wardenc.com

GLOBAL NETWORK



HEADQUARTER

Changwon Technical Center / R&D Center / Factory

153, Jeongdong-ro, Seongsan-gu, Changwon-si,
Gyeongsangnam-do, Korea (Zip Code : 51533)
TEL : +82 55 280 9114 FAX : +82 55 282 9680

Uiwang Technical Center / R&D Center

37, Cheoldobangmulgwan-ro, Uiwang-si, Gyeonggi-do,
Korea (Zip Code : 16082)
TEL : +82 31 596 8209 Fax : +82 55 210 9804

OVERSEAS OFFICES

HYUNDAI WIA Machine Tools America

265, Spring Lake Drive, Itasca, IL, 60143
TEL : +1 630 625 5600
FAX : +1 630 625 4733

Jiangsu HYUNDAI WIA

Company No.6 Fenghuang Road,
Fenghuang Town, Zhangjiagang City,
Jiangsu province, China
TEL : +86 512 5672 6808
FAX : +86 512 5671 6960

Chengdu Branch Office

NO.508 Room, B Block, AFC Plaza, NO.88
Jiaozi Road, High-tech Zone, Chengdu,
China
TEL : +86 028 8665 2985
FAX : +86 028 8665 2985

HYUNDAI WIA Machine Tools Europe

Kaiserleipromenade 5, 63067 Offenbach,
Germany
TEL : +49 69271 472 701
FAX : +49 69271 472 719

Hyundai WIA Machine Tools China Shanghai Branch Office

1-3F, Bldg6, No.1535 Hongmei Road,
Xuhui District, Shanghai, China
TEL : +86 021 6427 9885
FAX : +86 021 6427 9890

Qingdao Branch Office

Room 1207, Cai Fu Building, 182-6 Haier
Middle Road, Qingdao, China
TEL : +86 532 8667 9334
FAX : +86 532 8667 9338

Raunheim Service Center Raunheim R&D Center

Frankfurter. 63, 65479 Raunheim,
Germany
TEL : +49 6142 9256 111
FAX : +49 6142 9256 100

Beijing Branch Office

Floor 14, Zhonghangji Plaza B, No.15
Ronghua South Road, BDA Dist., Daxing
Dist., Beijing, China 100176
TEL : +86 010 8453 9850
FAX : +86 010 8453 9853

Wuhan Office

306-2, A Tower, Jiayu Gpmggian, No12
Chuangye Road, Economic Development
Zone, Wuhan, Hubei, China
TEL : +86 027 5952 3256
FAX : +86 027 5952 3256

India Branch Office

#4/169, Rajiv Gandhi Salai, (OMR),
Kandanchavadi, Chennai-600 096,
Tamilnadu, India
TEL: +91-44-3290-1719

Guangzhou Branch Office

Room 311, Unit 1-3, POLY TAL TU WUP,
Hanxi Avenue, Panyu District, Guangzhou,
China
TEL : +86 020 8550 6595
FAX : +86 020 8550 6597

Chongqing Office

Room 951, #3, Jinrongcheng T3, Jiangbei,
Chongqing, China
TEL : +86 23 6701 2970

www.warencnc.com



L2600SY Movie



L2600SY 3D Movie



<http://machine.hyundai-wia.com>

Head Office & Factory

153, Jeongdong-ro, Seongsan-gu, Changwon-si, Gyeongsangnam-do **Tel** +82 55 280 9500

Overseas Sales Team

16F, 37, Cheoldobangmulgwan-ro, Uiwang-si, Gyeonggi-do **Tel** +82 31 593 8173

HYUNDAI WIA Machine Tools America

265 Spring Lake Drive, Itasca, IL, 60143 **Tel** +1 (630) 625 5600 **Fax** +1 (630) 625 4733

HYUNDAI WIA Machine Tools Europe

Kaiserleipromenade 5, D-63067 Offenbach, Germany **Tel** +49 69271 472 701 **Fax** +49 69271 472 719

India Branch Office

#4/169, Rajiv Gandhi Salai, (OMR), Kandanchavadi, Chennai-600 096, Tamilnadu, India **Tel** +91 44 3290 1719