

# *MV65*

## *Short Magazine Barfeed*



### **STANDARD FEATURES:**

- Lathe spindle can be maximized
- Fast and smooth bar loading cycle
- Innovative linear guide insert pusher
- Removable hand held controller
- Touch screen with LCD display
- Floor mounted sliding rail
- Quick and accurate adjustment of bar diameters
- LED display for monitoring pusher position

 **Hydrafeed**

Secure push rod clamping



New design bar measuring and calibration system



Linear guide mounted loading mechanism



Hand held remote control with increased operator control



Sliding Rail – allows access to the rear of the lathe



Calibrated external adjustment of bar diameter settings

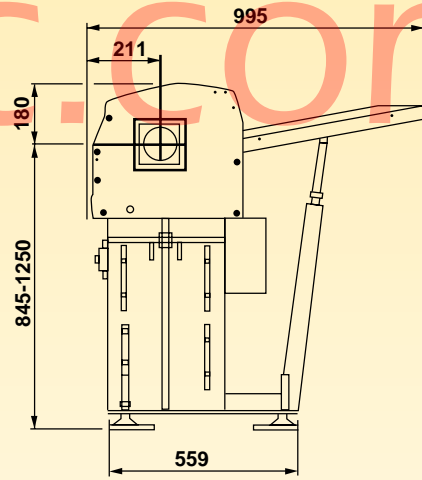
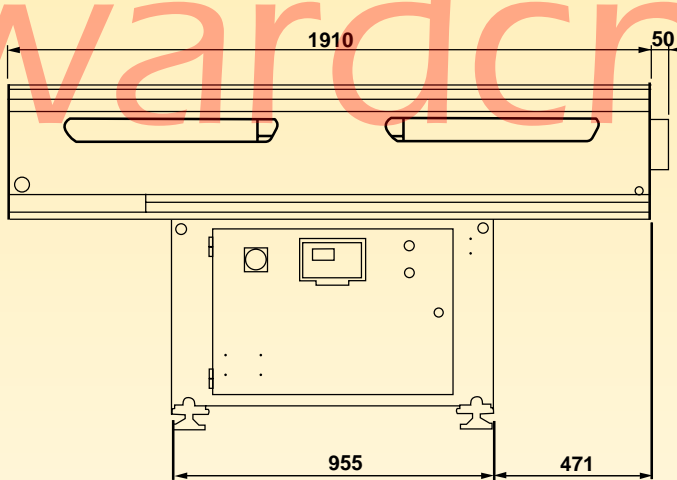

Bar Diameter	5 - 65mm
Bar Capacity	65mm / 10pcs
Bar Length	Max 1.5m Depending on machine spindle length

Machine Weight	280 KG
Air Pressure	6kg /cm2 70psi
Power Supply	220v / 380v / 400v / 415v / 440v

# Hydrafeed

Talgarth House, Bond Avenue, Mount Farm Industrial Estate, Milton Keynes. MK1 1JD  
 Tel: +44 (0)1908 376331 Fax: +44 (0)1908 647843  
 info@hydrafeed.co.uk www.hydrafeed.co.uk

